

NASA Contractor Report 182226

HASA—Hypersonic Aerospace Sizing Analysis for the Preliminary Design of Aerospace Vehicles

Gary J. Harloff and Brian M. Berkowitz

Sverdrup Technology, Inc.

NASA Lewis Research Center Group

Cleveland, Ohio

(NASA-CR-182226) HASA: HYPERSONIC AEROSPACE
SIZING ANALYSIS FOR THE PRELIMINARY DESIGN
OF AEROSPACE VEHICLES Final Contractor
Report (Sverdrup Technology) 60 p CSCI 01C

N89-15107

Unclas
G3/05 0184832

November 1988

Prepared for
Lewis Research Center
Under Contract NAS3-24105

NASA

National Aeronautics and
Space Administration

TABLE OF CONTENTS

	Page
Summary	1
Introduction	3
Nomenclature	6
Sizing Analysis	10
Weights Analysis	13
Vehicle Database	21
Results and Recommendations For Further Study	25
Conclusions	28
References	29
Figures 1-10	31-40
Tables 1-17	41-57

HASA - HYPERSONIC AEROSPACE SIZING ANALYSIS
FOR THE PRELIMINARY DESIGN OF AEROSPACE VEHICLES

Gary J. Harloff and Brian M. Berkowitz

Sverdrup Technology, Inc.
NASA Lewis Research Center Group
Cleveland, Ohio 44135

SUMMARY

A review of the hypersonic literature indicated that a general weight and sizing analysis was not available for hypersonic orbital, transport, and fighter vehicles. The objective of this study was to develop such a method for the preliminary design of aerospace vehicles. This report describes the developed methodology, and provides examples to illustrate the model, entitled the Hypersonic Aerospace Sizing Analysis (HASA). It can be used to predict the size and weight of hypersonic single-stage and two-stage-to-orbit vehicles and transports, and is also relevant for supersonic transports.

HASA is a sizing analysis that determines vehicle length and volume, consistent with body, fuel, structural, and payload weights. The vehicle component weights are obtained from statistical equations for the body, wing, tail, thermal protection system, landing gear, thrust structure, engine, fuel tank, hydraulic system, avionics, electrical system, equipment, payload, and propellant. Sample size and weight predictions are given for the Space Shuttle orbiter and other proposed vehicles, including four hypersonic transports, a Mach 6 fighter, a supersonic transport (SST), a single stage to-orbit (SSTO) vehicle, a two stage Space Shuttle with a booster and an orbiter,

and two methane-fueled vehicles. In addition, sample calculations of the size and weight of the vehicles are presented for various fuel and payload mass fractions. The propulsion systems considered include turbojets, turboramjets, ramjets, scramjets, and liquid-fuel rocket engines; the fuels include JP-4, RP-1, liquid hydrogen, liquid oxygen, liquid methane, hydrazine, and nitrogen tetroxide.

The results indicate that the method is accurate enough, $\pm 10\%$ of vehicle gross weight and length, to be used in preliminary designs and can predict absolute values and trends for hypersonic orbital, transport, and fighter vehicles. The model allows growth studies to be conducted with ease; examples of such studies are demonstrated herein.

INTRODUCTION

An important part of designing vehicles is predicting their size and weight. The design of SSTO vehicles presents a particular challenge because their performance is highly dependent on their size and weight, propulsion system, and aerodynamics. The need is for preliminary design techniques that can be used to estimate the size and weight of vehicles, and also be applied to a variety of propulsion systems and propellants. Both airbreathing and rocket-propulsion systems are of interest.

To assess the trade-offs between performance and size and weight in mission analysis studies, it is desirable to be able to change vehicle configurations with relative ease. An analytical model is needed that can predict a vehicle's size and weight requirements for various propulsion systems, payloads, propellant types, etc. See Cook (Ref. 1) for a thorough discussion of current methods.

Several weight prediction techniques have been developed using statistical correlations for specific vehicles. They include the Space Shuttle Synthesis Program - SSSP, 1970 (Ref. 2); the Weight Analysis of Advanced Transportation Systems Program - WAATS, 1974 (Ref. 3); and the Systems Engineering Mass Prediction Program - SEMP, 1979 (Ref. 4). The limitations of these programs are that SSSP and SEMP were developed explicitly for the Space Shuttle, while WAATS can predict only the weight but not the size of subsonic and supersonic vehicles.

A recent sizing method, which also evaluates the relative range of the vehicle, was developed by Fetterman in 1985 (Ref. 5) for subsonic, supersonic, and hypersonic aircraft. One of its drawbacks is that it requires an initial

baseline aircraft. As component changes are made, the aircraft size and weight are adjusted accordingly.

Other weight prediction programs developed by private industry and NASA require specific vehicle parameters and are usually coupled to vehicle synthesis programs. One NASA program that does not have these limitations is the weight prediction method for advanced hypersonic vehicles developed by Franciscus and Allen in 1972 (Ref. 6). While this method can be used to predict relative vehicle weights, it cannot be used to predict the size and weight of a new vehicle because the model coefficients must be recalibrated after vehicle details are provided. In addition, technological changes cannot be readily accounted for.

A review of the various computer models available for vehicle weight predictions suggested that a new preliminary weight/sizing prediction technique was needed that would cover a broad range of hypersonic vehicle configurations. Although a weight and sizing model applicable to all types of vehicles did not exist in mid-1986, several of the models reviewed were adequate for a specific class of vehicles if reliable designs were available to calibrate the model. It became desirable, then, to obtain a model which could (1) predict vehicle sizes and weights for both single-stage and two-stage-to-orbit vehicles, as well as transports and fighters; (2) account for different propulsion systems; (3) provide absolute values for vehicle sizes and weights; and (4) be able to account for changes in technology (i.e., materials and propulsion systems).

The Hypersonic Aerospace Sizing Analysis model presented here is designed to size and weigh various classes of hypersonic vehicles. Six classes

of vehicles are defined and considered for this study; they include hypersonic transports, hypersonic fighters, and supersonic transports, as well as single-stage-to-orbit, two-stage-to-orbit, and liquid methane vehicles. HASA can account for changes in the technology of materials and propulsion systems. It also incorporates the weights of various subsystems (e.g., hydraulics, avionics, electronics, and equipment) where other models do not. Most importantly, it provides absolute values for the vehicles it sizes.

NOMENCLATURE

A_{hfp}	ratio of horizontal stabilizer area/wing area
A_{lorb}	ratio of body cylinder length to body radius
AR	wing aspect ratio
A_{ratio}	rocket expansion ratio
A_{vfp}	ratio of vertical stabilizer area/wing area
B_b	body width, ft
B_{or}	ratio of span to body radius
C_{root}	chord at root, ft
D_{be}	equivalent body diameter, ft
F_r	body fineness ratio = L/D equivalent
H_{tsjm}	height of scramjet module, in
k_b	length calibration constant
k_c	calibration coefficient for non-idealized body
k_n	ratio of body depth/body width
L_b	total body length, ft
mf	modifying factor
N_{engrt}	number of rocket engines
N_{engsj}	number of scramjet modules
N_{engtj}	number of turbojet engines
N_{engtr}	number of turboramjet engines
Q_{max}	maximum dynamic pressure, lb/ft ²
S_{btot}	body wetted surface area, ft ²
S_{ref}	reference wing area (wing is considered to extend without interruption through the fuselage), ft ²

S_{tb}	one half body wetted surface area, ft ²
S_{wh}	horizontal stabilizer planform area, ft ²
S_{wv}	vertical stabilizer planform area, ft ²
t/c	wing thickness to chord ratio
T_{totrk}	total momentum thrust of all rocket engines, lb
T_{tott}	total momentum thrust of all airbreathing engines, lb
ULF	ultimate load factor
$V_{a. f.}$	volume of air factory, ft ³
V_{fuel}	volume of propellant, ft ³
V_{pay}	volume of payload, ft ³
V_{tot}	total vehicle volume, ft ³
W_a	engine airflow, lb/sec
W_b	weight of body structure, lb
W_{elect}	weight of electronics, lb
W_{emp}	vehicle empty weight, lb (dry)
W_{eng}	total engine weight, lb
W_{equip}	weight of onboard equipment, lb
W_{finh}	weight of horizontal stabilizer, lb
W_{finv}	weight of vertical stabilizer, lb
W_{fnitx}	weight of nitrogen tetroxide to take-off gross weight
W_{fuel}	total weight of propellant, lb
W_{gear}	weight of landing gear, lb
W_{gtot}	total vehicle gross weight, lb
W_{prop}/W_{gtot}	propellant weight fraction
W_{H_2}	weight of hydrogen to take-off gross weight

W_{hydr}	weight of hydraulics, lb
W_{hydZ}	weight of liquid hydrazine to take-off gross weight
W_{ins}	unit weight of thermal protection system, lb/ft ²
W_{O_2}	weight of oxygen to take-off gross weight
W_{pay}	weight of payload, lb
W_{pros}	total weight of propulsion system, lb
W_{rpl}	weight of RPI to take-off gross weight
W/S	wing loading, lb/ft ²
W_{span}	wingspan, ft
W_{str}	total weight of structural system, lb
W_{sub}	total weight of subsystems, lb
W_{taves}	weight of avionics, lb
W_{thrst}	total weight of thrust structure, lb
W_{thrua}	weight of airbreathing thrust structure, lb
W_{thrur}	weight of rocket engine thrust structure, lb
W_{tnk}	total weight of propellant tanks, lb
W_{tps}	weight of thermal protection system, lb
W_{trj}	weight of ramjet engines, lb
W_{trt}	weight of rocket engines, lb
W_{tsj}	weight of scramjet engines, lb
W_{ttj}	weight of turbojet engines, lb
W_{ttr}	weight of turboramjet engines, lb
W_w	weight of wing structure, lb

Greek Symbols

δ	= 0 if no fuel is stored in the fuselage
δ	= 1 if all of the fuel is stored in the fuselage
λ	wing taper ratio
$\lambda_{1/2}$	mid-chord sweep angle, deg
η_{vol}	vehicle volumetric efficiency
ρ_a	vehicle density $(W_{gtot} - W_{fuel} - W_{pay})/V_{tot}$, lb/ft ³
ρ_f	density of hydrogen fuel, lb/ft ³
ρ_{hy}	density of hydrazine, lb/ft ³
ρ_{ni}	density of nitrogen tetroxide lb/ft ³
ρ_{o_2}	density of oxygen lb/ft ³
ρ_{rp}	density of RP-1/JP-4, lb/ft ³
ρ_{tank}	density of propellant tank, lb/ft ³
ρ_{t_h}	density of hydrogen tank, lb/ft ³
ρ_{t_o}	density of oxygen tank, lb/ft ³
θ_f	fore cone half angle, deg
	θ_r aft cone half angle, deg

SIZING ANALYSIS

A new model, the Hypersonic Aerospace Sizing Analysis (HASA), was developed in which vehicle sizing is obtained by iteratively solving for the vehicle volume, wetted area, length, and equivalent diameter, following the approach of Oman (Ref. 7). The operating empty body volume, V_{tot} , is the sum of the empty body volume, the fuel volume, the payload volume, and the air factory volume, i.e.,

$$V_{tot} = \frac{W_{gtot} - \delta W_{fuel} - W_{pay} - \delta W_{tnk} - W_{tps}}{\rho_a} + \delta V_{fuel} + V_{pay} + V_{a.f.}$$

where:

W_{gtot} is the total take-off gross weight, W_{fuel} is the fuel weight, W_{pay} is the payload weight, W_{tnk} is the fuel tank weight, W_{tps} is the thermal protection weight, V_{fuel} is the fuel volume, V_{pay} is the payload volume, $V_{a.f.}$ is the air factory volume, ρ_a is the vehicle density, and δ is 1 if all the fuel is stored in the fuselage and 0 if none of the fuel is in the fuselage. (Most of the vehicles in this study have fuel stored in their bodies, except for the SST, which has all of its fuel in its wings.)

The total wetted area of the body is defined as:

$$S_{tot} = 3.309 k_c \sqrt{L_b V_{tot}}$$

where 3.309 is for an idealized Hack body of revolution, and k_c is the calibration coefficient for a non-idealized shape. The total length of the body is determined from the following equation:

$$L_b = k_b \left(\frac{F_r^2 V_{tot}}{\frac{\pi}{4} \eta_{vol}} \right)^{1/3}$$

where k_b is a length calibration constant and η_{vol} is the vehicle volumetric efficiency, typically 0.7. The HASA model's results are not particularly sensitive to η_{vol} .

The vehicle fineness ratio is defined as:

$$F_r = L_b/D_{be}$$

where the body equivalent diameter is:

$$D_{be} = \sqrt{\frac{V_{tot}}{L_b \frac{\pi}{4} \eta_{vol}}}$$

and the body width, B_b , is related to D_{be} by the equation:

$$B_b = \frac{2 D_{be}}{1 + k_n}$$

where k_n is the ratio of the depth/width.

The constants k_c , k_b , and k_n are determined by equating the actual vehicle S_{btot} , L_b , and V_{tot} with the idealized vehicle. The fore and aft body half angles, θ_f and θ_r , are measured from top view drawings where available. A_{lorb} is defined as the ratio of the length of the constant diameter portion of the body divided by its body radius. The equations equating the actual and idealized vehicle for S_{btot} , volume, and radius follow:

The S_{btot} equation is:

$$3.309 k_c \sqrt{I_b V_{tot}} = \frac{2D_{bc}^2}{(1+k_n)^2} \left| \frac{\pi/2}{\sin \theta_f} + (\pi)\Lambda_{lorb} + \frac{\pi/2}{\sin \theta_r} \right|$$

The length equation is:

$$I_b k_b = \left| \frac{R}{\tan \theta_f} + (R)(\Lambda_{lorb}) + \frac{R}{\tan \theta_r} \right|$$

And finally the volume equation is:

$$\frac{W_{gtot} - \delta W_{fuel} - W_{pay} - \delta W_{tk}}{\rho_a} + \delta V_{fuel} + V_{pay} + V_{a.f.}$$

$$= \left(\frac{D_{bc}}{1+k_n} \right)^3 2\pi \left(\frac{1}{6 \tan \theta_f} + \frac{\Lambda_{lorb}}{2} + \frac{1}{6 \tan \theta_r} \right)$$

Solving for k_n , k_c , and k_b , which are iteratively solved as the vehicle weight changes, results in:

$$k_n = D_{bc} \left| \frac{2\pi \left(\frac{1}{6 \tan \theta_f} + \frac{\Lambda_{lorb}}{2} + \frac{1}{6 \tan \theta_r} \right)}{\left(\frac{W_{gtot} - \delta W_{fuel} - W_{pay}}{\rho_A} + \delta V_{fuel} + V_{pay} + V_{a.f.} \right)^{1/3}} \right| - 1$$

$$k_c = \frac{2 D_{bc}^2}{(1+k_n)^2} \left(\frac{\pi/2}{\sin \theta_f} + \pi \Lambda_{lorb} + \frac{\pi/2}{\sin \theta_r} \right) \frac{1}{3.309 \sqrt{I_b V_{tot}}}$$

$$k_b = \frac{\left(\frac{D_{bc}}{1+k_n} \right) \left(\frac{1}{\tan \theta_f} + \Lambda_{lorb} + \frac{1}{\tan \theta_r} \right)}{I_b}$$

WEIGHTS ANALYSIS

A goal of the current study is to develop a preliminary design methodology capable of handling a wide spectrum of hypersonic vehicle configurations. Several classes of vehicles, including hypersonic transports, single-stage-to-orbit vehicles, two-stage-to-orbit vehicles, supersonic transports, liquid methane vehicles, and hypersonic fighters, were considered for both horizontal and vertical take-off configurations.

To obtain a good approximation of the total vehicle weight that is consistent with the preliminary design, the vehicle weight is divided into 14 individual components. The weight for each component is obtained from statistical weight equations. These components include the propellant, body, wing, horizontal and vertical stabilizers, thrust structure, propellant tank, landing gear, propulsion, thermal protection system, avionics, hydraulics, electronics, equipment, and payload. The weight analysis model uses the iterative method described in the previous section. The vehicle is first iteratively sized according to the sizing analysis described above, and then weighed. Each weight component has a separate weight equation except for payload weight and volume, which are inputs into the analysis. Unless otherwise noted, all weights are in units of pounds.

Body Weight

The basic body weight includes major structural components but does not include the thrust structure or propellant tanks. The basic body weight equation has a coefficient to accommodate vehicle skin temperatures between 1500° and 2000°F (Ref. 3). The modifying factor (mf) can also account for changes in the technology of materials. Figure 1 shows mf as a function of the

structural temperature for various materials, including aluminum, titanium, and Rene 41.

The body weight equation is as follows:

$$W_b = 0.341 mf(o)^{1.0}$$

where

$$o = \left[\left(\frac{L_b U L F}{D_{br}} \right)^{0.15} \left(Q_{max} \right)^{0.16} \left(S_{btot} \right)^{1.05} \right]$$

The primary structure of the vehicles included in this study was aluminum except for the SST, which was constructed of titanium. For those vehicles with an integral tank assembly, the body weight is equal to the tank weight, as is further discussed in the tank weight equation described below.

Wing Weight

The wing weight equation includes the weight of the wing box structure, the aerodynamic control surfaces, and the wing carry-through structure. The wing weight equation (Ref. 7), which accounts for the wing aspect ratio and the taper ratio, is a function of the empty weight of the vehicle.

The empty weight of the vehicle is defined as:

$$W_{emp} = W_{pnt} + W_{fuel}$$

and the wing weight equation is as follows:

$$W_w = 2958 (mf) \left\{ \left[\frac{W_{emp} U L F}{1000} \right]^{5.7} \left[S_{ref} \right]^7 \left[AR \right]^{4.7} \left[\frac{1+A}{A/c} \right]^4 \left[3 + \frac{7}{\cos(\Lambda_{1/2})} \right] \right\}^{1.017}$$

The coefficient 0.2958 and the exponent 1.017 were developed as part of this study, and ULF is the ultimate load factor. For integral tanks in the wing, the empty weight is defined as:

$$W_{emp} = W_{emp} - W_{tank}$$

Tail Weight

The weight of the horizontal and vertical stabilizers (tails) includes the aerodynamic control surfaces (Ref. 3). The weight of the horizontal stabilizer is:

$$W_{finh} = 0.0035 (\Lambda)^{1.0}$$

where

$$\Lambda = \left[\left(\frac{W_{glot}}{S_{ref}} \right)^{0.6} (S_{wh})^{1.2} (Q_{max})^{0.8} \right]$$

and the weight of the vertical stabilizer is:

$$W_{finv} = 5.0 (S_{wlv})^{1.09}$$

Thermal Protection System Weight

The thermal protection system is assumed to cover an area equal to the sum of the planform area of the wing, the horizontal stabilizer, and half of the wetted surface area of the body. An average unit weight per unit area (W_{ins}) is assumed for the entire TPS area. The TPS weight is defined as:

$$W_{tps} = W_{ins}(S_{th} + S_{ref} + S_{wh})$$

where S_{lb} is the lower half of the body wetted surface area, S_{ref} is the planform area of the wing, and S_{wh} is the planform area of the horizontal stabilizer.

Landing Gear Weight

The landing gear weight is defined as the weight of the nose gear, the main gear, and the controls. The landing gear weight is dependent on either the vehicle gross weight or the empty weight, depending on whether the vehicle takes off horizontally or vertically. The landing gear weight (Ref. 3) is calculated as:

$$W_{gear} = 0.00916(W_{gtot})^{1.124}$$

For a vertical take-off vehicle, W_{emp} is substituted for W_{gtot} in the above equation.

Thrust Structure Weight

The thrust structure supports the airbreathing and rocket engines. Its weight is a function of the total momentum thrust of all airbreathing and rocket engines. For airbreathing engines, the weight of the thrust structure (Ref. 3) is:

$$W_{thrua} = 0.00625(T_{tot}) + 69.0$$

For rocket engines, the weight of the thrust structure is:

$$W_{thrua} = 0.0025(T_{totrk})$$

Total Structural Weight

Thus the total structural weight is the sum of the body, the wing, the horizontal and vertical tail, the thermal protection system, the landing gear, and the thrust structure, as follows:

$$W_{str} = W_b + W_w + W_{finh} + W_{finv} + W_{tps} + W_{gear} + W_{thrst}$$

Engine Weight

Hypersonic vehicles will probably employ more than one type of propulsion system. This report considers five different propulsion systems, including the turbojet, the turboramjet, the ramjet, the scramjet, and the rocket. Table 1 shows the various combinations of propulsion systems considered for this study. The HASA model calculates an engine weight that is dependent on engine performance characteristics and independent of its location on the airframe. The weight equations for each of the propulsion systems are listed below. (Inlet weight is ignored for this analysis.)

The turbojet weight equation, determined from data in Ref. 8, is as follows:

$$W_{tj} = \frac{N_{eng} (W_a (133.3) - 16600)}{4}$$

For this report, all airbreathing turbine engines were weighed using the turbojet weight equation.

The turboramjet weight equation, developed for GE 12/JZ8 engine (Ref. 3), is as follows:

$$W_{tr} = N_{eng} 1782.63 (e)^{0.003(W_a)}$$

The ramjet weight equation is:

$$W_{trj} = 0.01 (T_{tot})$$

The value 0.01 is representative of a low volume ramjet with a thrust/weight ratio of 100:1 (Ref. 3).

The scramjet weight equation, taken from Ref. 9, is:

$$W_{tsj} = N_{engsj} (87.5 H_{tsjm} - 850.0)$$

It is a function of the module height, H_{tsjm} .

The rocket weight equation, which is based on an LR-129 LO₂/LH₂ engine (Ref. 3), is as follows:

$$W_{trt} = 0.00766(T_{totrk}) + 0.00033(T_{totrk})(A_{ratio})^{0.5} + 130(N_{engrt})$$

Note that this report uses a fixed propulsion system (i.e., the weight of the propulsion system scales with airflow and thrust and not with the take-off gross weight). For vehicles with several propulsion systems, it is unclear how each individual system would vary; clearly, the systems will scale differently with different vehicle gross weights.

Tank Weight

The tank weights are assumed to be proportional to the tank volume. Tanks that are an integral part of the vehicle body (integral tanks) are assumed for cryogenic fuels. The tank weight equation is defined as:

$$W_{tank} = \sum \rho_{tank} V_{fuel} + \text{fuel tank insulation}$$

where tanks for H₂, O₂, hydrazine, CH₄, and N₂O₄ are accounted for.

Fuel tank insulation, which prevents cryogenic fuel boil-off, is not accounted for in this report. This insulation weight would be proportional to the internal surface area of the tank.

Total Propulsion Weight

The total propulsion weight is the weight of the engines plus the weight of the propellant tanks:

$$W_{\text{pros}} = W_{\text{tank}} + W_{\text{eng}}$$

Subsystem Weight

Some additional weight components not included in the Franciscus and Allen model are the weight of the hydraulics, avionics, electronics, and equipment. In most cases, these secondary weight components comprise a nominal 5% to 10% of the total gross weight. The sum of these weights is defined as the subsystem weight; their equations are given below (unless otherwise noted, all subsystem weight equations were taken from Ref. 3):

Hydraulic Weight

The weight of the hydraulics is defined as:

$$W_{\text{hydr}} = 2.64 (\psi)^{1.0}$$

where

$$\psi = \left[\left(\frac{(S_{\text{ref}} + S_{\text{wlv}} + S_{\text{wth}}) Q_{\text{max}}}{1000} \right)^{0.334} \left(I_b + W_{\text{system}} \right)^{0.5} \right]$$

Avionics Weight

The weight of the avionics is defined as:

$$W_{\text{avcs}} = 66.37 (W_{\text{gtot}})^{0.361}$$

Electrical System Weight

The weight of the electrical system is defined as:

$$W_{\text{elect}} = 1.167 (0)^{1.5}$$

where

$$0 = \left[(W_{\text{gtot}})^{0.5} (L_b)^{0.25} \right]$$

Equipment Weight

The weight equation for the equipment, taken from Ref. 6, is:

$$W_{\text{equip}} = 10000 + 0.01(W_{\text{gtot}} - 3.0000003)$$

The total subsystem weight is thus defined as:

$$W_{\text{sub}} = W_{\text{hydr}} + W_{\text{avcs}} + W_{\text{elect}} + W_{\text{equip}}$$

Payload

The payload weight and volume are input data to the model. Typical payload densities are about 3.3 lb/ft³.

Propellant Weight

The propellant weight is calculated as a function of the vehicle gross weight. Both fuel and oxidizer mass fractions are input data to the model.

The fuel and oxidizer weights are calculated as the product of the gross weight and the mass fraction of the fuel or oxidizer.

Total Vehicle Gross Weight

The total vehicle gross weight is thus defined as:

$$W_{\text{tot}} = W_{\text{fuel}} + W_{\text{str}} + W_{\text{pay}} + W_{\text{pros}} + W_{\text{sub}}$$

VEHICLE DATABASE

A literature search was conducted to obtain a vehicle database to assess the accuracy of the HASA model. A limited number of hypersonic vehicles were available in the open literature. (The lack of detailed vehicle weight breakdown and vehicle geometry is noted.) Eight hypersonic vehicles and one supersonic vehicle were defined. They include 4 HST's, 1 SSTO, 3 TSTO-type vehicles, and the Boeing 2707 SST. A Mach 6 fighter and a methane-fueled Mach 6 fighter and transport were also included to illustrate the HASA model's sensitivity to various vehicle parameters. The vehicle database is summarized in Table 2.

Hypersonic Transports

HSTs will probably take off and land horizontally on conventional runways. These passenger-carrying vehicles will operate at hypersonic speeds generally at altitudes above 100000 feet. All of the HST vehicles considered for this study were taken from the same generation of conceptual designs suggested by NASA Langley (Ref. 10, circa 1967). They operate at a

cruise speed of around Mach 6 and have long, slender elliptical-shaped bodies with fineness ratios ranging from 12 to 16. A 200-passenger, 42000-pound payload was proposed for each of the four vehicles, which are sized primarily to accommodate the large liquid-hydrogen fuel tanks that fuel turbojet/ramjet or turbojet/scramjet propulsion systems.

Trade studies by the Lockheed-California Company were performed on many of the proposed NASA Langley hypersonic vehicle configurations to determine their feasibility (Refs. 11 and 12). Three vehicles from the Lockheed studies, known as the Hycat series, were identified for the HASA study because they contained a detailed weight breakdown and vehicle geometry.

The first vehicle, the Hycat-1, is a 200-passenger, horizontal take-off transport shown in Figure 2a. It has a reference length of 389 feet, a wingspan of 109.2 feet, and a total gross weight of 773706 pounds. The propulsion system consists of a turbojet/ramjet configuration. (Note that this proposed vehicle does not have a horizontal stabilizer.)

Hycat-1A, shown in Figure 2b, is an optimized design of the Hycat-1. The Hycat-1A is a 200-passenger, horizontal take-off transport with a reference length of 344.9 feet, a wingspan of 96.2 feet, and a total gross weight of 613174 pounds. This vehicle is very similar to the Hycat-1 except that a horizontal stabilizer was added to this configuration. It also has a turbojet/ramjet propulsion system.

The 200-passenger Hycat-4, shown in Figure 2c, is somewhat different from the previous two vehicles in that it has a much larger wingspan of 146.7

Rockwell Space Division performed a trade study for a vehicle configuration similar to that of the Hycat series (Ref. 13). The Rockwell vehicle (Figure 2d) is a 200-passenger, horizontal take-off transport with an elliptical shaped body, a reference length of 300 feet, a wingspan of 112.5 feet, and a total gross weight of 481400 pounds. A turbojet/scramjet propulsion system is mounted on its body.

Single-State-to-Orbit Vehicles

SSTO vehicles are defined as fully re-useable vehicles that may take off horizontally or vertically and reach orbital flight with one stage of propulsion. Martin Marietta (Refs. 14, 15, and 16) performed a study for several SSTO configurations proposed by NASA Langley. One of these configurations was chosen for this study. It is a vertical take-off vehicle which is powered by eight dual-mode liquid hydrogen/liquid oxygen rocket engines. Designated the SSTO parallel burn vehicle (see Figure 3), it has a reference length of 149.4 feet, a wingspan of 114.3 feet, and a gross take-off weight of 2325607 pounds. A large fraction of the total vehicle volume is used for liquid hydrogen and liquid oxygen propellant tanks. The payload bay is 15 feet by 60 feet and is equivalent in size to that of the Space Shuttle.

Two-Stage-to-Orbit Vehicle

TSTO vehicles can be defined as earth-to-orbit vehicles that require two stages to achieve orbital flight. The Space Shuttle is a vertical take-off vehicle that is propelled by a pair of solid rocket boosters. A large external fuel tank feeds the liquid hydrogen/liquid oxygen rocket engines (Ref. 17) of the orbiter (see Figure 4), which has a reference length of 107.5 feet. Liquid hydrazine

and nitrogen tetroxide, used primarily for orbital maneuvers, is the onboard propellant. The main propulsion system includes the three SSME engines.

A space shuttle system proposed by General Dynamics' Convair Division is another TSTO vehicle considered (Refs. 18 and 19). Figure 5 illustrates the launch configuration, which is made up of both an orbiter and a booster element. For this study, each vehicle was analyzed separately. The proposed orbiter, shown in Figure 6a, has a reference length of 179.2 feet and a wingspan of 146.9 feet. The wings are located inside the body until after re-entry, and deploy for landing. The orbiter is a re-usable vehicle with a rocket/turbofan propulsion system used primarily for low-earth orbit landing maneuvers. The payload bay is 15 feet by 60 feet and the total vehicle gross weight is reported to be 891795 pounds. The proposed booster configuration, shown in Figure 6b, is a large, re-useable fuel tank that can land horizontally like the orbiter, and is powered by 15 liquid hydrogen/liquid oxygen rocket engines. The reference length is 210 feet and the wingspan is 201 feet. The booster's wings are located inside its body until landing, when four turbofans are used for low-earth orbit maneuvers. Since the booster element does not reach orbital trajectories, no payload bay is provided. With the large amount of fuel onboard the booster, the total gross weight is 3335275 pounds.

Supersonic Transport

Figure 7 illustrates the proposed Boeing 2707 SST (Ref. 20) designed for 290 passengers. It has a 69000-pound payload with four turbofan engines mounted about the center section of the wings, which carry JP-4 propellant. The vehicle has a reference length of 315 feet, a wingspan of 126.8 feet, and a total gross weight of 640000 pounds.

Vehicle Description Summary

Table 3 is the vehicle description summary for each of the 12 vehicles presented in this study. The geometry input consists of the fore and aft body cone angles, the payload weight and volume, wing loading, vehicle fineness ratio, thickness to chord ratio, and aspect ratio. Some of the propulsion descriptors include the number of each type of engine, the engine airflow in lb/sec, the engine expansion ratio, and the total thrust for airbreathing and rocket engines. Other descriptors include the propellant mass fractions, the propellant and tank densities, and the aircraft density.

RESULTS AND RECOMMENDATIONS FOR FURTHER STUDY

The results of this study are divided into five sections. The first section presents and compares weight and size predictions, using HASA, for eight hypersonic vehicles and one supersonic vehicle. The second, third, and fourth sections present model sensitivities and the results of applying the model to these nine vehicles plus 3 hypothetical hypersonic vehicles. Finally, the fifth section offers recommendations for further study.

HASA Weight Prediction

HASA was used to predict the size and weight of several proposed hypersonic vehicles including 4 HSTs, an SSTO vehicle, 3 TSTO vehicles, and an SST. The weight predictions are compared to the published values in Tables 4 to 12. The overall model accuracy is $\pm 10\%$ of vehicle gross weight and length; however, the detailed component weight error is larger. These predictions are within the accuracy needed for preliminary designs. Furthermore, the

current model can predict absolute vehicle size and weight without needing to recalibrate the model for each vehicle.

Sensitivity Studies

Vehicle size and weight was predicted for a Mach 6 fighter vehicle to illustrate the sensitivity of vehicle size and weight to fuel mass fraction. The fuel mass, for the Mach 6 vehicle (Ref. 21), was varied from 0.1 to 0.65. Figure 8 illustrates the predicted gross weight as a function of the fuel mass fraction. By comparing the predicted weight and length with the reported values, a model accuracy assessment can be made. The predicted gross weight as a function of vehicle length is shown in Figure 9, with the circle representing the Mach 6 vehicle. The Mach 6 vehicle lies very close to the HASA model. These results illustrate the ability of the HASA model to predict absolute vehicle size and weight.

Methane Fueled Vehicles

The current model can be used to assess the impact of fuel density on vehicle size and weight. As an example, the Hycat-4 vehicle, originally sized for liquid H₂ fuel, is resized using HASA by changing the fuel from liquid hydrogen to methane. The LH₂ density at -184°F is 22.16 lb_m/ft³ and at -139°F is 17.92 lb_m/ft³. Compare Table 6 with Table 13 to see the effect of fuel density on vehicle size and weight. Only the fuel density has been changed. The HASA predicted vehicle weight decreases from 1 million pounds to 550600 pounds and the length increases from 392 feet to 409 feet. The equivalent diameter decreased from 28 feet to 16 feet.

A similar study was done with the Mach 6 fighter discussed previously. Liquid hydrogen was replaced with methane fuel and the vehicle was resized. The results can be seen by comparing Tables 14 and 15. Again, only the fuel density has been changed. The predicted weight decreases from 311000 pounds to 255000 pounds when H₂ fuel is replaced by CH₄ fuel, and the length increases from 185 feet to 304 feet. The equivalent diameter decreased from 22 feet to 12 feet. In each of the examples presented above, the methane-fueled vehicles were lighter and smaller in diameter than the same vehicles fueled with liquid hydrogen. This result is reasonable because the density of methane is greater, and therefore, both its volume and the required structural weight are less.

Sensitivity Study for Payload and Fuel Loading

The HASA model is used to assess the relationship of vehicle size and weight to payload and fuel loadings. Table 16 shows the results of changing the payload from 50% to 200% of the design values. In each case, as the payload is increased, the vehicle gross weight increased linearly. This result is most likely a consequence of the payload being a small fraction of the vehicle weight.

An analysis of the relationship between fuel loading and weight was also conducted using the HASA model because scaling vehicles is central to preliminary design. Table 17 and Figure 10 shows typical results of perturbing the vehicle about its design point by varying the fuel loading from 80% to 120% of the design values (see Table 3). This study illustrates the utility of the HASA model. Figure 10 reveals that the vehicle gross weight does not increase linearly with increased fuel loading. This is consistent with the

authors' other sensitivity studies showing the effect of fuel loading on vehicle gross weight (see Figure 9).

Recommendations for Further Study

In the future, both better definition of the engine and inlet weights and simple equations to predict the engine weight, as vehicle size changes, are needed. In addition, the engine airflow and thrust levels are currently held constant for each vehicle, independent of vehicle size; however, variable engine weights should be incorporated into the analysis and might be accomplished by varying the airflow or the thrust of each propulsion system with variations in vehicle size and weight. Finally, additional studies are recommended for SST and HST vehicles, especially where titanium or other non-aluminum metals are used. Because the entire statistical database used for this report is based on aluminum technology, it may be inappropriate for non-aluminum vehicles. Thus more fundamental weight analyses may be warranted in the preliminary design phase than is afforded by the statistical approach used here.

CONCLUSIONS

A general vehicle weight and sizing model has been developed for a broad range of vehicles which does not require a detailed weight breakdown or model recalibration. The weight and sizing methodology presented here can be used in flight trajectory studies where the flight trajectory, aerodynamics, weight, and propulsion systems vary according to specified values of vehicle weight, size, length, and fuel loading for a given mission.

REFERENCES

1. Cook, E.L.: "An Exploratory Investigation of Weight Estimation Techniques for Hypersonic Flight Vehicles," NASA CR-184420, June 1981.
2. Anon.: "Space Shuttle Synthesis Program (SSSP). Volume II -- Weight/Volume Handbook," NASA CR-114987, 1970.
3. Glatt, C.R.: "WAATS-A Computer Program for Weights Analysis of Advanced Transportation Systems," NASA CR-2420, Sept. 1974.
4. Klich, P.J., and MacConochie, I.O.: "Mass Estimating Techniques for Earth-to-Orbit Transports with Various Configuration Factors and Technologies Applied," SAWE Paper No. 1315, 1979.
5. Fetterman, D.E., Jr., "Preliminary Sizing and Performance of Aircraft," NASA TM 86357, July, 1985.
6. Franciscus, L.C., and Allen, J.L.: "Upper-Stage Space-Shuttle Propulsion by Means of Separate Scramjet and Rocket Engines," NASA TND-6762, May 1972.
7. Oman, B.H., "Vehicle Design Evaluation Program," NASA CR-145070, January 1977.
8. Whitlow, J.B. Jr., Eisenberg, J.D., and Shovlin, M.D.: "Potential of Liquid-Methane Fuel for Mach 3 Commercial Supersonic Transports," NASA TN D-3471.
9. Jones, R.A., and Huber, P.W.: "Toward Scramjet Aircraft -- Progress in Engine Development," NASA 78A23421, Feb. 1978.
10. Penland, J.A., Edwards, C.L., and Witcofski, R.D.: "Comparative Aerodynamic Study of Two Hypersonic Cruise Aircraft Configurations Derived From Trade-Off Studies," NASA TM X-1436, October 1967.
11. Morris, R.E., and Brewer, G.D.: "Hypersonic Cruise Aircraft Propulsion Integration Study, Vol. I," NASA CR-158926-1, Sept. 1979.
12. Morris, R.E., and Brewer, G.D.: "Hypersonic Cruise Aircraft Propulsion Integration Study, Vol. II," NASA CR-158926-2, Sept. 1979.
13. Repic, E.M., Olson, G.A., and Milliken, R.J.: "A Methodology for Hypersonic Transport Technology Planning," NASA CR-2286, Sept. 1973.

14. Haefei, R.C., Ernest, G.L., Hurley, J.B., and Winter, M.G.: "Technology Requirements for Advanced Earth-Orbital Transportation Systems," NASA CR-2866, Oct. 1977.
15. Haefei, R.C., Ernest, G.L., Hurley, J.B., and Winter, M.G.: "Technology Requirements for Advanced Earth-Orbital Transportation Systems," NASA CR-2867, Oct. 1977.
16. Haefei, R.C., Ernest, G.L., Hurley, J.B., and Winter, M.G.: "Technology Requirements for Advanced Earth-Orbital Transportation Systems, Dual-Mode Propulsion," NASA CR-2868, Oct. 1977.
17. Whitnah, A.M.Y., and Hillje, E.R.: "Space Shuttle Wind Tunnel Testing Program Summary," NASA Ref. Pub. 1125, Nov. 1984.
18. Anon.: "Space Shuttle Final Technical Report: Volume II Final Vehicle Configuration," NASA CR-102550, Oct. 1969.
19. Anon.: "Space Shuttle Final Technical Report: Volume V Subsystems and Weights Analysis," NASA CR-102537, Oct. 1969.
20. Walkley, K.B., et al. "Concept Development of a Mach 2.7 Advanced Technology Transport Employing Wing-Fuselage Blending," NASA CR-165739, Dec. 1981.
21. Brewer, G.D., Sherrer, M., and Morris, R.E.: "A Study of Propulsion Systems for Hypersonic Cruise Vehicles," Lockheed Aircraft Company, LAC-602466, June 1965.

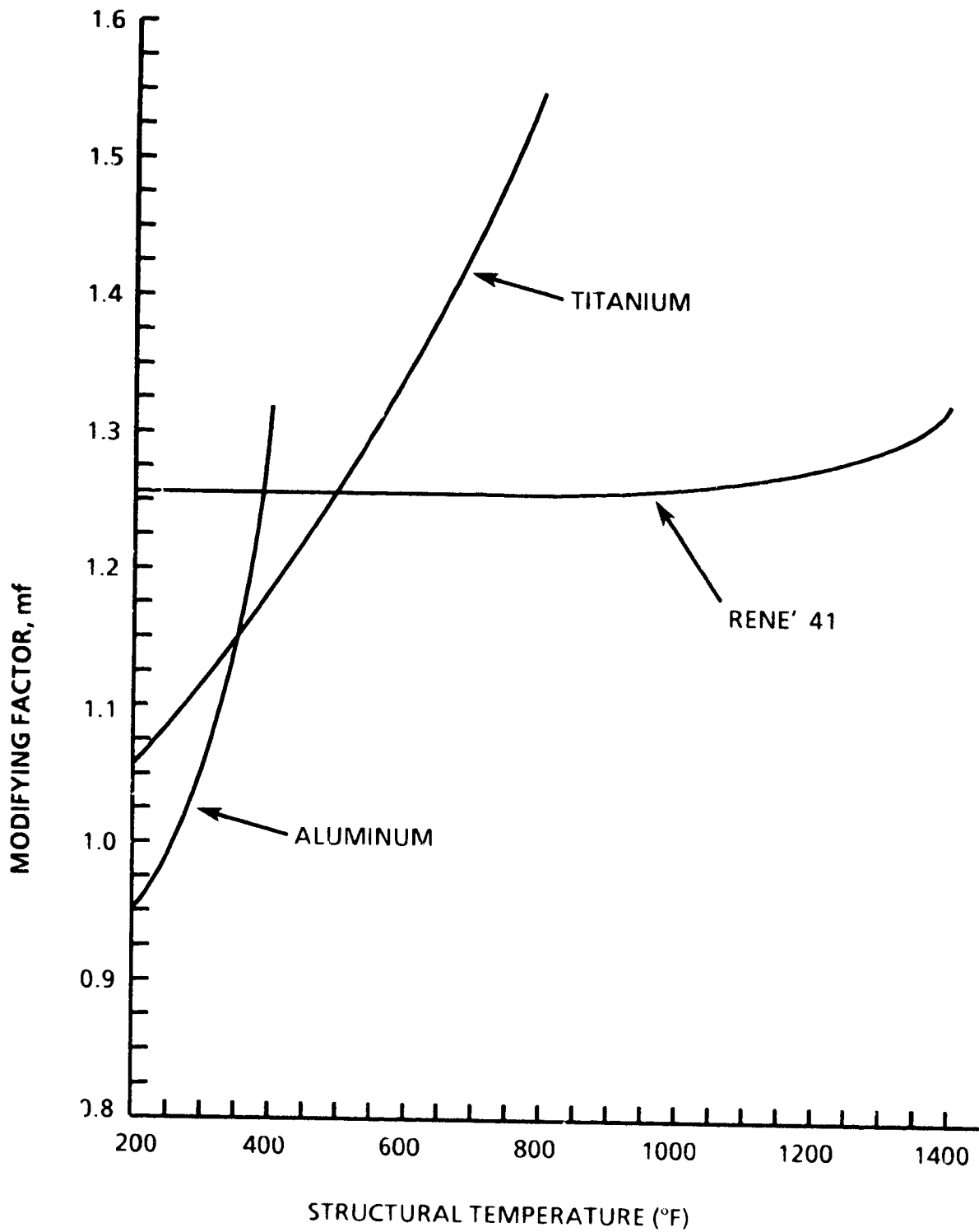
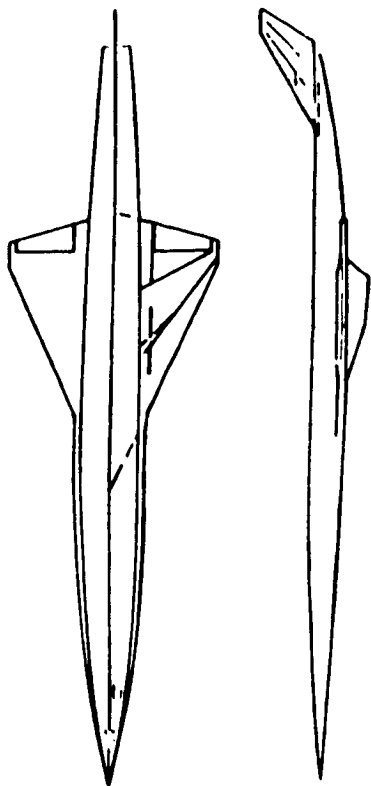
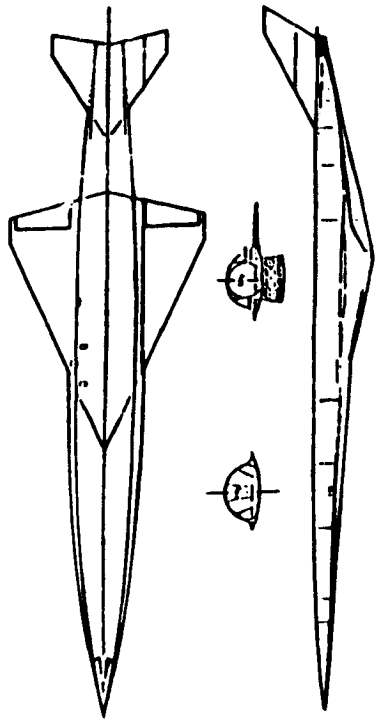

Figure 1
MODIFYING FACTOR FOR BASIC BODY WEIGHT COEFFICIENT



A. Lockheed Hycat - 1 Hypersonic Transport



B. Lockheed Hycat - 1A Hypersonic Transport

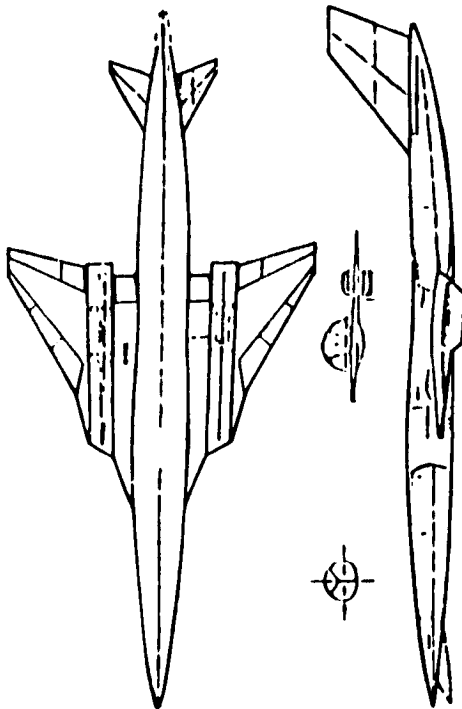

C. Lockheed Hycat - 4 Hypersonic Transport

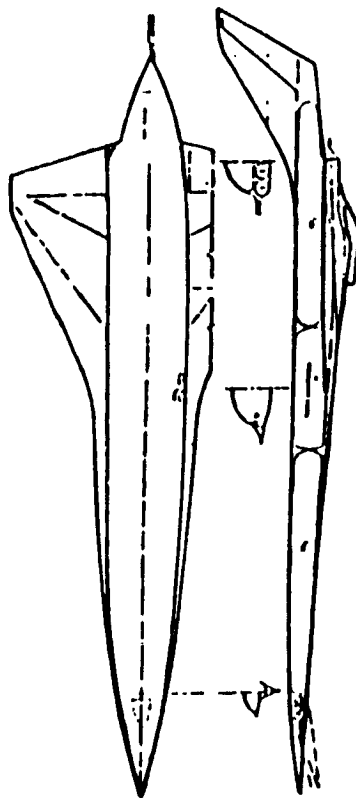

D. Rockwell Hypersonic Transport

Figure 2
PROPOSED HYPERSONIC TRANSPORTS

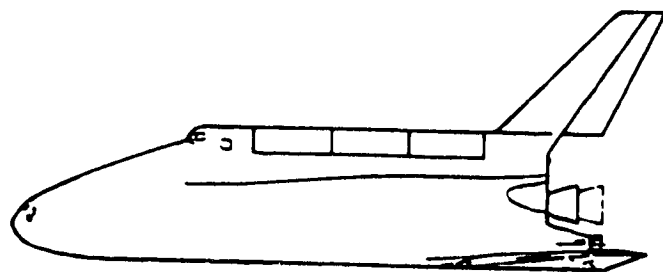
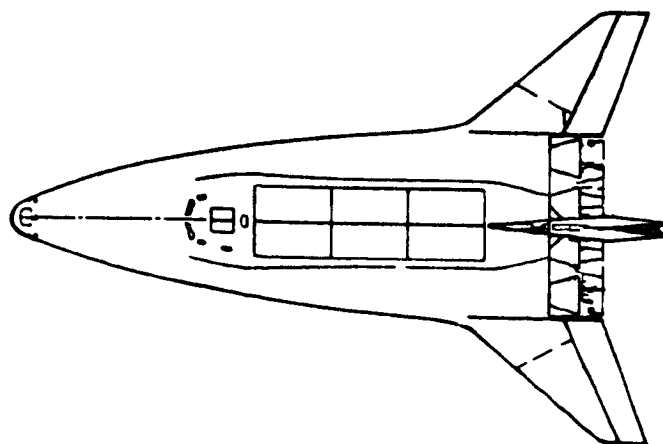

Martin Marrietta Parallel Burn SSTO

Figure 3
PROPOSED SINGLE-STAGE-TO ORBIT (SSTO) VEHICLE

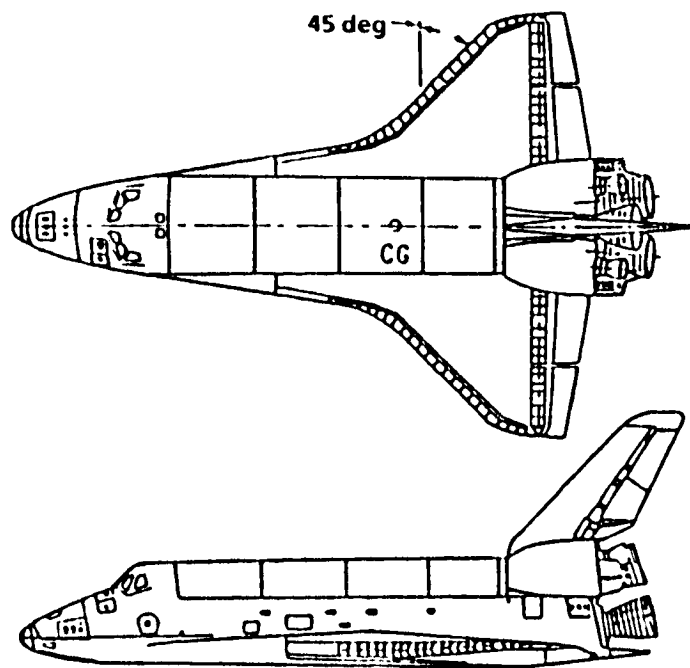

Figure 4
SPACE SHUTTLE ORBITER

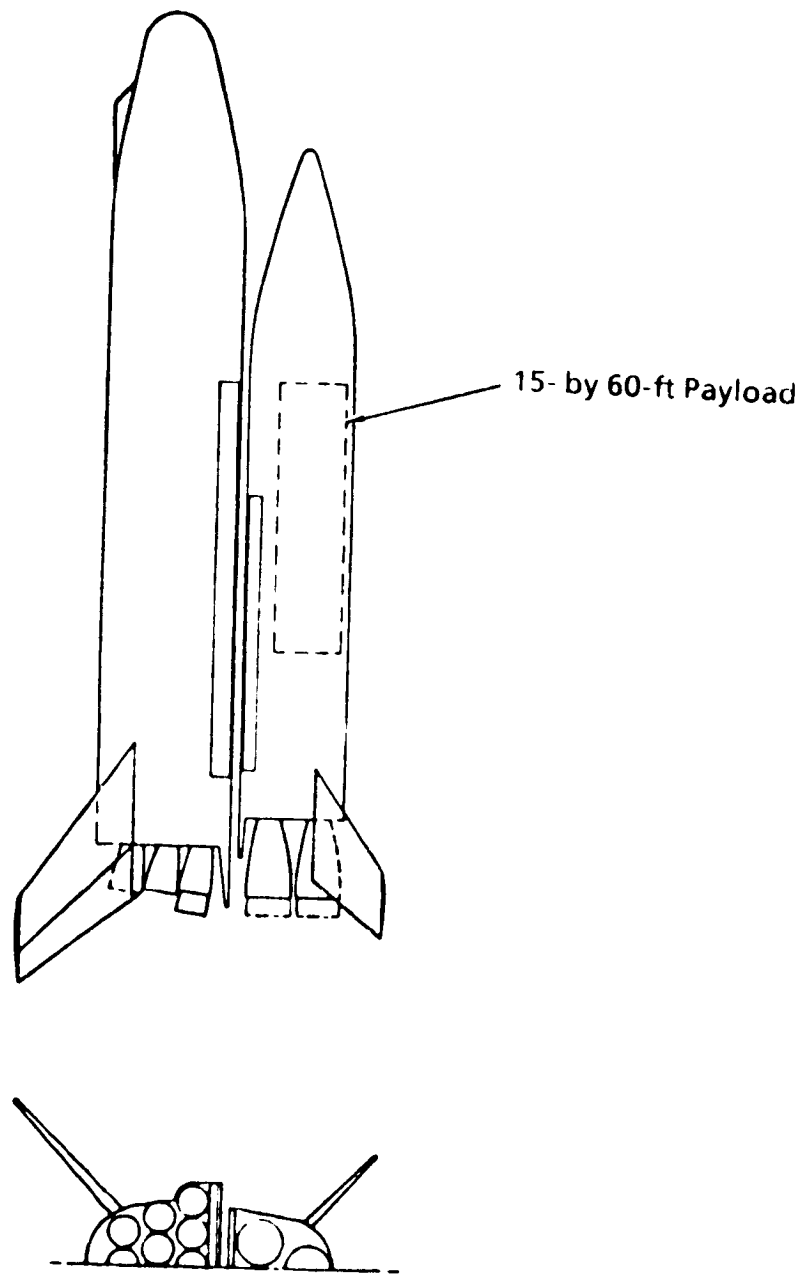
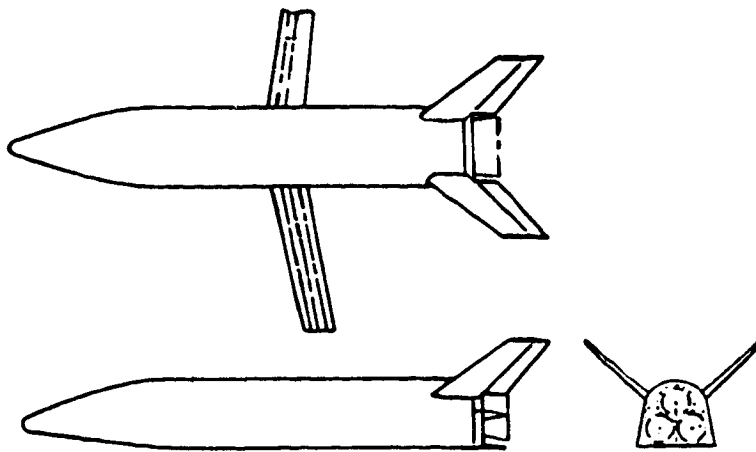
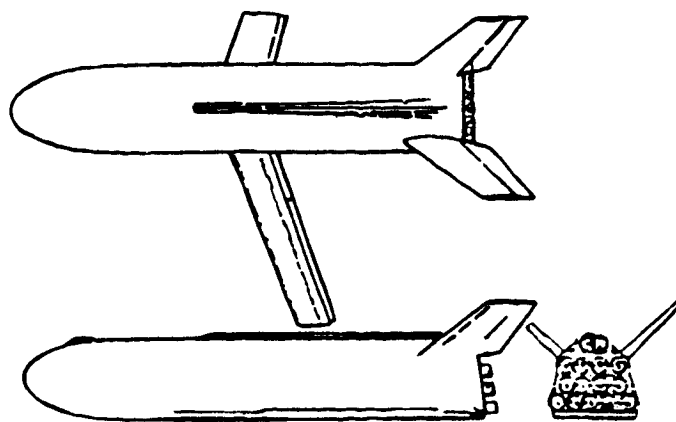

Figure 5
GENERAL DYNAMICS PROPOSED SHUTTLE CONFIGURATION



A. General Dynamics FR - 3 Orbiter Element



B. General Dynamics FR - 3 Booster Element

Figure 6
PROPOSED TWO-STAGE-TO ORBIT VEHICLES

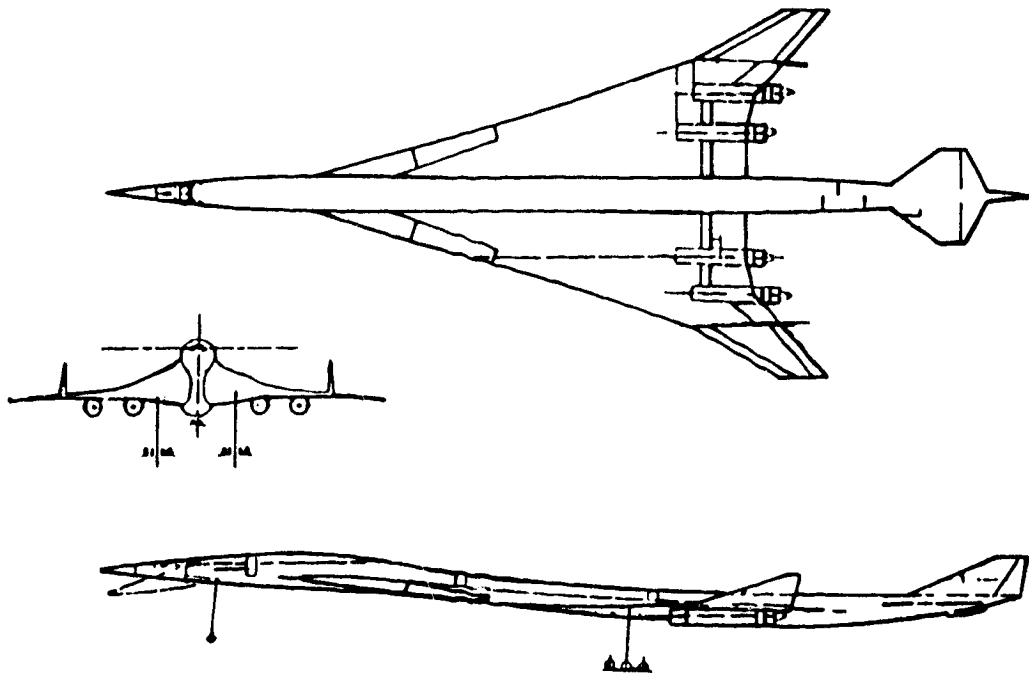

Figure 7
PROPOSED SUPERSONIC TRANSPORT

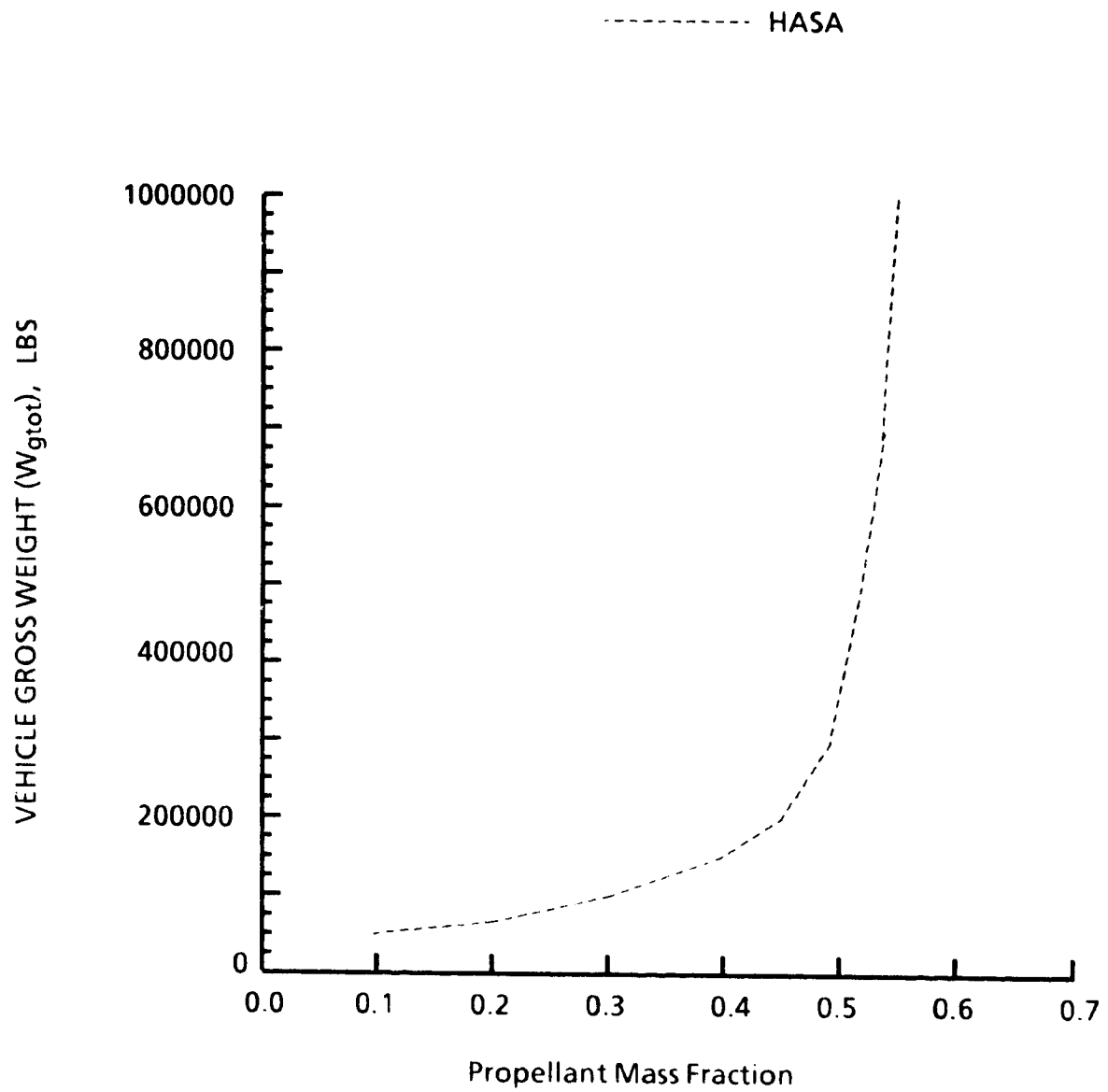

Figure 8
VEHICLE GROSS WEIGHT vs PROPELLANT MASS FRACTION

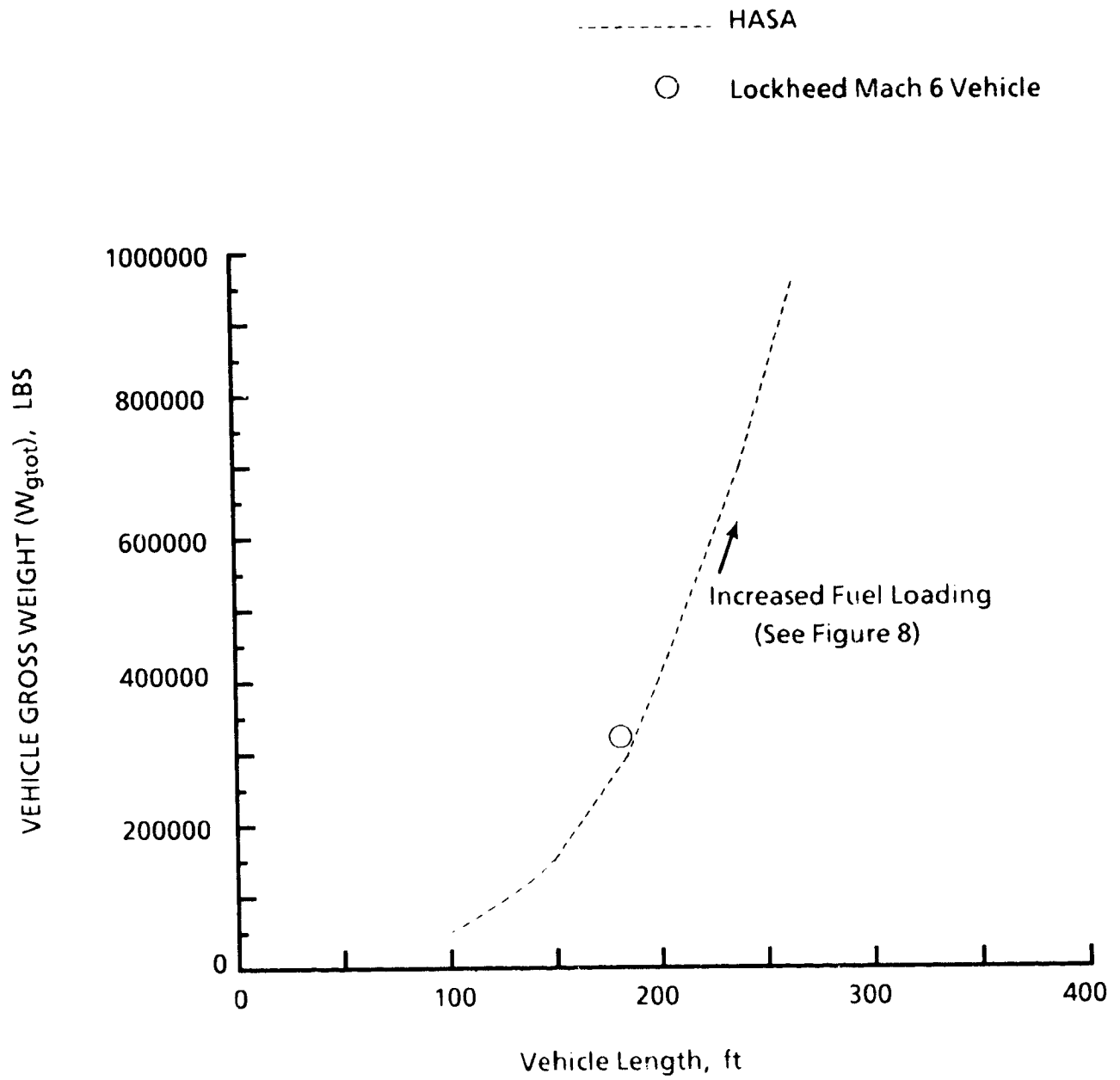

Figure 9
VEHICLE GROSS WEIGHT vs VEHICLE LENGTH

VEHICLE GROSS WEIGHT (W_{gtot}), LBS

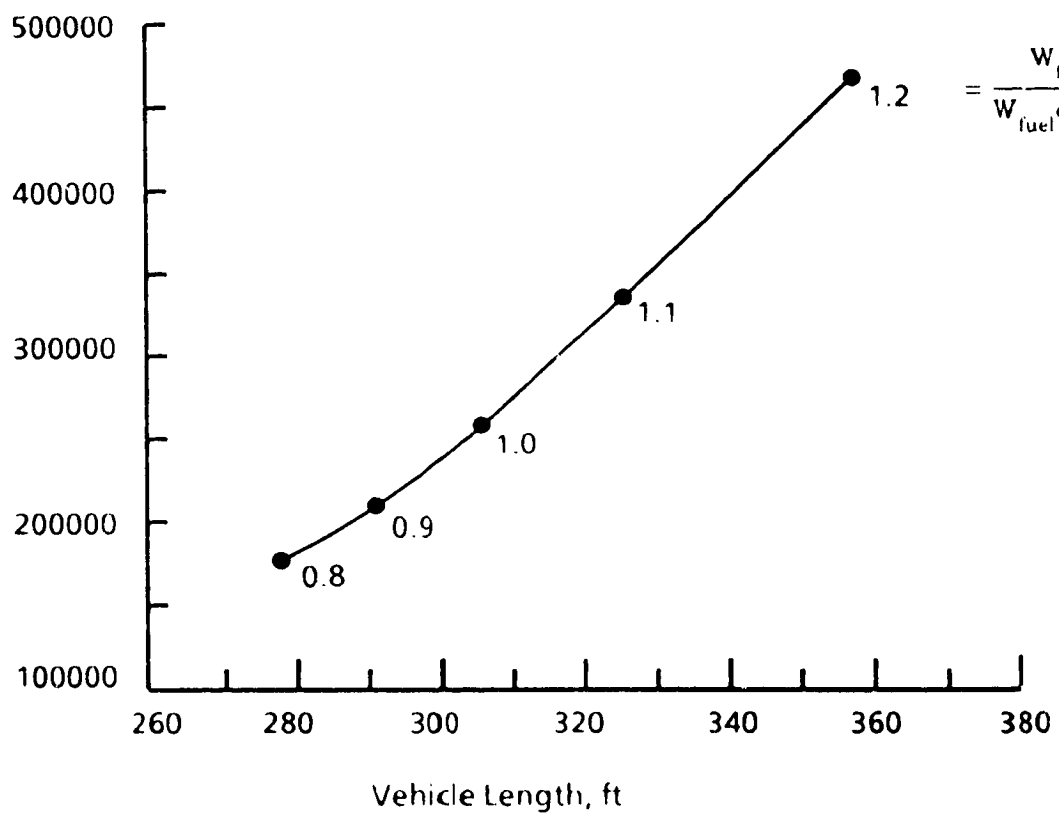

Figure 10
WEIGHT vs LENGTH OF CH₄ FIGHTER, M = 6 FOR VARIOUS
FUEL LOADINGS (see Table 17)

Table 1
PROPULSION SYSTEM COMBINATIONS

LTOT	PROPULSION TYPE(S)
1	TURBOJET
2	RAMJET
3	ROCKET
4	TURBOJET/RAMJET
5	TURBOJET/SCRAMJET
6	TURBOJET/ROCKET
7	ROCKET/RAMJET
8	ROCKET/SCRAMJET
9	ROCKET/TURBOJET/SCRAMJET
10	ROCKET/TURBOJET/RAMJET

Table 2
SUMMARY OF VEHICLE CONFIGURATIONS

	ROCKWELL	HYCAT-1A	HYCAT-1	HYCAT-4	SHUTTLE	...G.D. ORBITER	...G.D. BOOSTER	MARTIN MARIETTA	BOEING SST
Gross Takeoff Weight, lb	481400	613174	773706	959426	255170	891795	3402316	2325607	640000
Reference Length, ft	300	344.9	389.5	340	107.5	179.2	210	149.4	315
Wing Span, ft	117.5	96.2	109.24	146.68	78	146.9	201	114.6	126.84
Body Diameter, ft	23.4	24.46	24.46	24.46	21	28.68	30.4	28.28	12.46
Reference Wing Area, ft ²	9323	7129.9	8792	9594	3103	1781	3459	2276	8447
Sweep Angles, deg	65	65	65	60	81/45	10	20	50	70
Taper Ratio	0.145	0.154	0.099	0.13	0.2	0.8	0.84	0.31	0.096
Chord, ft (root)	110	90	147	121	57.44	13.5	18.7	39.2	168.2
Thickness/chord	0.03	0.03	0.03	0.03	0.11	0.21	0.21	0.1	0.03
Length/Diameter	12.82	14.10	15.92	13.90	5.12	6.25	5.33	5.28	25.28
Aspect Ratio, b ² /s	1.357	1.357	1.357	2.24	1.961	12.12	11.68	5.87	1.904
Tail Area, ft	1020	1875	971	2095	510	1397	2285	895	1002
Body Wetted Area, ft ²	19000	21997	25857	22077	5634	14900	26610	16406
Body Volume, ft ³	* 81606	* 91434	* 103582	* 143324	34347	89060	236000	* 103162	* 32566
Passengers	200	200	200	200	0	0	0	0	290
Fuel/Gross Weight	0.3178	0.3488	0.3709	0.3792	0.1274	0.7092	0.8403	0.8816	0.4748
Sp/V ^{2.3}	5.20	3.50	3.60	3.59	1.80	1.05	1.05	1.02	8.55
(Thrust/Weight)	0.48	0.50	0.50	0.45	++ 5.53	1.66	2.10	0.70	0.33
M ₀ Design	6	6	6	6	25	25	25	2.7

* Calculated

.. Excludes external fuel, tanks and solid rocket boosters

... Combined at lift off, e.g. 2 stage vehicle

**Table 3
VEHICLE DESCRIPTION SUMMARY**

INPUT LIST	ROCKWELL	HYCAT-1A	HYCAT-1	HYCAT-4	SHUTTLE	G.D. ORBITER	G.D. BOOSTER	MARTIN MARETTA	BOEING SST	CH ₄ , M-6 FIGHTER	CH ₄ , M-6 TRANSPORT	H ₂ , M-6 FIGHTER
PROPELLANT MASS FRACTION:												
W _{hyd}	0	0	0	0	0.0637	0	0	0	0	0	0	0
W _{nit}	0	0	0	0	0.0637	0	0	0	0	0	0	0
W _{H₂} (or CH ₄)	0.3178	0.3488	0.3709	0.3772	0	0.0955	0.1124	0.0743	0	0.461	0.461	0.5
W _{O₂}	0	0	0	0	0	0.6104	0.7307	0.7276	0	0	0	0
W _{rp1}	0	0	0	0	0	0.0033	0.014	0.0797	0.4708	0	0	0
GEOMETRY:												
A _{hp}	0	0.1366	0	0.063	0	0.784	0.66	0	0.09	0.066	0.066	0.13
A _{vp}	0.11	0.1125	0.12	0.16	0.13	0.0	0.0	0.22	0.04	0.106	0.106	0
A _{orb}	12.82	8.65	9.89	10.63	8.33	8.15	8.85	5.37	32.3	35.54	35.54	0.77
AR	1.357	1.357	1.357	2.24	1.96	12.12	11.68	5.87	1.904	1.7	2.24	1.698
C _{root}	110	90	147	121	57.44	13.5	18.7	39.2	168.5	87.3	87.3	78.5
FR	12.82	14.1	15.92	13.90	5.12	6.25	5.32	3.9	25.3	27.3	27.3	6.05
λ _{1/2}	43	40	43	50	21	10	18	37	58	51	51	50
θ _r	8.02	4.04	3.95	5.37	27.7	12.97	28.96	22.29	7.54	4	4	6.35
θ _r	9.90	10.48	7.61	8.69	0	0	0	0	4.28	12	12	23.3
v _c	0.03	0.03	0.03	0.03	0.11	0.21	0.21	0.1	0.03	0.025	0.025	0.03
λ	0.145	0.154	0.099	0.13	0.2	0.8	0.84	0.31	0.096	0.107	0.107	0.276
V _{pay}	16000	13860	13860	13860	34350	10633	0	10603	18940	1602	13860	1500
W _{pay}	50000	42000	42000	42000	72258	50000	0	65000	60610	5000	42000	5000
W/S	51.6	86	88	100	71.75	145.6	137.8	123.7	75.77	86	86	80.78
PROPULSION:												
A _{ratio}	0	0	0	0	77.5	35	35	55	0	0	0	12
H _{13pm}	36.48	0	0	56.9	0	0	0	0	0	14	14	42
N _{engrt}	0	0	0	0	3	3	15	8	0	0	0	3
N _{engaj}	9	0	0	8	0	0	0	0	0	4	4	6
N _{engtj}	4	4	4	4	0	3	4	0	4	4	4	0
T _{totrt}	0	0	0	0	1410000	1E+06	6930000	1628000	0	0	0	475000
T _{totj}	232000	306000	386000	430000	0	63000	210000	0	210000	129314	129314	150000
W _a	400	551	551	551	0	425	425	0	443	225	225	0
PROPELLANT & TNK DENSITY:												
ρ _a	7.0	7.0	7.0	7.0	4.0	4.0	4.0	4.0	44.0	7.0	7.0	7
ρ _f (H ₂ or CH ₄)	5.25	5.25	5.25	5.25	0	4.5	4.5	4.5	0	22.16	22.16	4.5
ρ _{hy}	0	0	0	0	1	0	0	0	0	0	0	0
ρ _{ni}	0	0	0	0	1	0	0	0	0	0	0	0
ρ _{rp}	0	0	0	0	0	1.7	1.0	1.0	0.88	0	0	0
ρ _{th}	1.00	1.75	1.25	1.75	0	1.7	1	1.0	0	1.75	1.75	1
ρ _{ta}	0	0	0	0	0	2.13	1.25	1.2	0	0	0	0
MISCELLANEOUS:												
Q _{max}	1000	1000	1000	1000	1000	1000	1000	1000	1000	1000	1000	1000
W _{ins}	1.00	1.50	1.50	1.50	3.00	3.00	2.15	2.85	0.00	1.5	1.5	1
ULF	3.75	3.75	3.75	3.75	5.25	5.25	5.25	5.25	3.75	3.75	3.75	3.75
mf	1.12	1.12	1.12	1.12	1.12	1	1	1.12	2.0	1.12	1.12	1

Table 4
VEHICLE CONFIGURATION: LOCKHEED HYCAT-1

GEOMETRY	Actual	Model
Vehicle Length, Forward Cone, ft	177.00	179.94
Vehicle Length, Cylinder, ft	121.00	122.79
Vehicle Length, Aft Cone, ft	91.50	93.00
TOTAL VEHICLE LENGTH, ft	389.50	395.73
Equivalent Diameter, ft	24.46	21.82
Length/Diameter *	15.92	15.94
Wing Area, S_{ref} , ft ²	8792.00	7923.20
Wing Span, b, ft	109.24	103.69
Aspect Ratio = b^2/S_{ref} *	1.357	1.357
Wing Loading, W_{gross}/S_{ref} *	88.00	88.00
Tail Area, ft ²	971.00	950.00
Body Wetted Area, ft ²	25857.00	20263.00
Volume Required, ft ³	---	103582.00
Volume Payload, ft ³ *	13860.00	13860.00
WEIGHTS	Actual	Model
Payload, lb *	42000.00	42000.00
Fuel Tank, lb	71748.00	86203.00
Turbojet, lb	69598.00	56782.00
Ramjet, lb	5930.00	3860.00
Scramjet, lb	---	---
Rocket, lb	---	---
Propulsion, lb	155680.00	146845.00
Body, lb	92757.00	90485.00
Wing, lb	60676.00	55965.00
Horiz, Vert. Tail, lb	14845.00	8812.00
Thermal Protection System, lb	33966.00	27082.00
Landing Gear, lb	28711.00	33873.00
Thrust Structure, lb	3909.00	2482.00
Structure, lb	234864.00	218699.00
Hydrogen, lb	286991.00	258608.00
Oxygen, lb	---	---
Other, lb	---	---
Fuel, lb	286991.00	258608.00
Avionics, lb	---	8540.00
Hydraulics, lb	---	1229.00
Electronics, lb	---	4346.00
Equipment, lb	---	16972.00
Subsystems, lb	54127.00	31087.00
TOTAL TAKE OFF GROSS WEIGHT, lb	773706.00	697239.00

* Denotes Input

Table 5
VEHICLE CONFIGURATION: LOCKHEED HYCAT-1A

GEOMETRY	Actual	Model
Vehicle Length, Forward Cone, ft	173.01	176.01
Vehicle Length, Cylinder, ft	105.81	107.45
Vehicle Length, Aft Cone, ft	66.11	67.20
TOTAL VEHICLE LENGTH, ft	344.90	350.66
Equivalent Diameter, ft	24.46	21.78
Length/Diameter *	14.10	15.94
Wing Area, S_{ref} , ft ²	7129.90	7100.30
Wing Span, b, ft	96.20	98.16
Aspect Ratio = b^2/S_{ref} *	1.357	1.357
Wing Loading, W_{gtail}/S_{ref} *	86.00	86.00
Tail Area, ft ²	1875.00	1768.70
Body Wetted Area, ft ²	21997.00	17929.30
Volume Required, ft ³	---	91434.50
Volume Payload, ft ³ *	13860.00	13860.00
WEIGHTS	Actual	Model
Payload, lb *	42000.00	42000.00
Fuel Tank, lb	53469.00	70996.00
Turbojet, lb	54901.00	56782.00
Ramjet, lb	4620.00	3060.00
Scramjet, lb	---	---
Rocket, lb	---	---
Propulsion, lb	120098.00	130838.00
Body, lb	74670.00	78166.00
Wing, lb	45626.00	48377.00
Horiz., Vert. Tail, lb	12481.00	12173.00
Thermal Protection System, lb	26918.00	25552.00
Landing Gear, lb	23895.00	29181.00
Thrust Structure, lb	3098.00	1982.00
Structure, lb	186688.00	195431.00
Hydrogen, lb	213875.00	212987.00
Oxygen, lb	---	---
Other, lb	---	---
Fuel, lb	213875.00	212987.00
Avionics, lb	---	8140.00
Hydraulics, lb	---	1165.00
Electronics, lb	---	3946.00
Equipment, lb	---	16106.00
Subsystems, lb	50514.00	29357.00
TOTAL TAKE OFF GROSS WEIGHT, lb	613174.00	610611.00

* Denotes Input

Table 6
VEHICLE CONFIGURATION: LOCKHEED HYCAT-4

GEOMETRY	Actual	Model
Vehicle Length, Forward Cone, ft	130.00	149.80
Vehicle Length, Cylinder, ft	130.00	149.50
Vehicle Length, Aft Cone, ft	80.00	92.13
TOTAL VEHICLE LENGTH, ft	340.00	391.50
Equivalent Diameter, ft	24.46	28.14
Length/Diameter *	13.90	13.90
Wing Area, S_{ref} , ft ²	9594.00	9819.80
Wing Span, b, ft	146.68	148.31
Aspect Ratio = b^2/S_{ref} *	2.150	2.240
Wing Loading, W_{gut}/S_{ref} *	100.00	100.00
Tail Area, ft ²	2095.00	2184.90
Body Wetted Area, ft ²	22077.00	23982.00
Volume Required, ft ³	---	143284.00
Volume Payload, ft ³ *	13860.00	13860.00
WEIGHTS	Actual	Model
Payload, lb *	42000.00	42000.00
Fuel Tank, lb	91100.00	123467.00
Turbojet, lb	68673.00	56782.00
Ramjet, lb	---	---
Scramjet, lb	25329.00	33030.00
Rocket, lb	---	---
Propulsion, lb	186416.00	213280.00
Body, lb	105831.00	105147.00
Wing, lb	107849.00	110542.00
Horiz., Vert Tail, lb	8339.00	18323.00
Thermal Protection System, lb	33966.00	33637.00
Landing Gear, lb	34283.00	49776.00
Thrust Structure, lb	13180.00	2756.00
Structure, lb	277562.00	320180.00
Hydrogen, lb	361860.00	370403.00
Oxygen, lb	---	---
Other, lb	---	---
Fuel, lb	361860.00	370403.00
Avionics, lb	---	9663.00
Hydraulics, lb	---	1413.00
Electronics, lb	---	5144.00
Equipment, lb	---	19820.00
Subsystems, lb	91588.00	36040.00
TOTAL TAKE OFF GROSS WEIGHT, lb	959426.00	981981.00

* Denotes Input

Table 7
VEHICLE CONFIGURATION: ROCKWELL VEHICLE

GEOMETRY	Actual	Model
Vehicle Length, Forward Cone, ft	59.70	81.63
Vehicle Length, Cylinder, ft	197.90	147.34
Vehicle Length, Aft Cone, ft	42.40	65.90
TOTAL VEHICLE LENGTH, ft	300.00	294.88
Equivalent Diameter, ft	23.40	22.44
Length/Diameter *	12.83	12.82
Wing Area, S_{ref} , ft ²	9323.00	9769.20
Wing Span, b, ft	112.50	115.14
Aspect Ratio = b^2/S_{ref} *	1.357	1.357
Wing Loading, W_{gw}/S_{ref} *	51.60	51.60
Tail Area, ft ²	1020.00	1047.60
Body Wetted Area, ft ²	19000.00	16024.00
Volume Required, ft ³	---	81606.00
Volume Payload, ft ³ *	16000.00	16000.00
WEIGHTS	Actual	Model
Payload, lb *	50000.00	50000.00
Fuel Tank, lb	40490.00	30514.00
Turbojet, lb	37000.00	36654.00
Ramjet, lb	---	---
Scramjet, lb	16200.00	21078.00
Rocket, lb	---	---
Propulsion, lb	93690.00	88246.00
Body, lb	61410.00	67386.00
Wing, lb	32600.00	58080.00
Horiz., Vert Tail, lb	6900.00	10070.00
Thermal Protection System, lb	26700.00	17781.00
Landing Gear, lb	18100.00	23524.00
Thrust Structure, lb	---	1519.00
Structure, lb	145710.00	178360.00
Hydrogen, lb	153000.00	160200.00
Oxygen, lb	---	---
Other, lb	---	---
Fuel, lb	153000.00	160200.00
Avionics, lb	3200.00	7596.00
Hydraulics, lb	---	1191.00
Electronics, lb	7800.00	3433.00
Equipment, lb	28000.00	15041.00
Subsystems, lb	39000.00	27261.00
TOTAL TAKE OFF GROSS WEIGHT, lb	481400.00	504068.00

* Denotes Input

Table 8
VEHICLE CONFIGURATION: SPACE SHUTTLE ORBITER

GEOMETRY	Actual	Model
Vehicle Length, Forward Cone, ft	20.00	24.53
Vehicle Length, Cylinder, ft	87.50	107.17
Vehicle Length, Aft Cone, ft	---	---
TOTAL VEHICLE LENGTH, ft	107.50	131.72
Equivalent Diameter, ft	21.00	28.79
Length/Diameter	5.12	5.12
Wing Area, S_{ref} , ft ²	3103.30	2751.60
Wing Span, b, ft	78.00	73.44
Aspect Ratio = b^2/S_{ref}	1.961	1.961
Wing Loading, * W_{klut}/S_{ref}	71.75	71.75
Tail Area, ft ²	510.00	366.00
Body Wetted Area, ft ²	5634.00	10298.00
Volume Required, ft ³	34347.00	60030.00
Volume Payload, ft ³ *	10603.00	10603.00
WEIGHTS	Actual	Model
Payload, lb *	72258.00	72258.00
Fuel Tank, lb + Thrust St	---	---
Turbojet, lb	---	---
Ramjet, lb	---	---
Scramjet, lb	---	---
Rocket, lb	33888.00	15287.00
Propulsion, lb	33888.00	15287.00
Body + Tank, lb	42941.00	38028.00
Wing, lb	15098.00	12523.00
Horiz., Vert. Tail, lb	2848.00	3113.00
Thermal Protection System, lb	21187.00	23702.00
Landing Gear, lb	7713.00	8202.00
Thrust Structure, lb	---	3525.00
Structure, lb	89787.00	89093.00
Hydrogen, lb	---	---
Oxygen, lb	---	---
Other, lb	32516.00	28825.00
Fuel, lb	32516.00	28825.00
Avionics, lb	5946.00	5688.00
Hydraulics, lb	1855.00	555.00
Electronics, lb	10132.00	1881.00
Equipment, lb	8788.00	12263.00
Subsystems, lb	26721.00	20387.00
TOTAL TAKE OFF GROSS WEIGHT, lb	255170.00	226272.00

* Denotes Input

Table 9
VEHICLE CONFIGURATION: GENERAL DYNAMICS ORBITER

GEOMETRY	Actual	Model
Vehicle Length, Forward Cone, ft	62.30	57.680
Vehicle Length, Cylinder, ft	116.90	108.180
Vehicle Length, Aft Cone, ft	---	---
TOTAL VEHICLE LENGTH, ft	179.20	165.87
Equivalent Diameter, ft	28.68	27.82
Length/Diameter	6.248	6.250
Wing Area, S_{ref} , ft ²	1781.00	1792.10
Wing Span, b, ft	146.90	147.38
Aspect Ratio = b^2/S_{ref}	12.12	12.12
Wing Loading, * W_{kwl}/S_{ref} *	145.63	145.63
Tail Area, ft ²	1397.00	1405.00
Body Wetted Area, ft ²	14900.00	12037.00
Volume Required, ft ³	89060.00	70569.00
Volume Payload, ft ³ *	10633.00	10633.00
WEIGHTS	Actual	Model
Payload, lb *	50000.00	50000.00
Fuel Tank, lb	49355.00	46806.00
Turbojet, lb	13834.00	29990.00
Ramjet, lb	---	---
Scramjet, lb	---	---
Rocket, lb	16110.00	14001.00
Propulsion, lb	79299.00	90796.00
Body, lb**	0.00	0.00
Wing, lb	23093.00	22290.00
Horiz., Vert Tail, lb	11027.00	21930.00
Thermal Protection System, lb	37901.00	27647.00
Landing Gear, lb	12245.00	11222.00
Thrust Structure, lb	6088.00	4003.00
Structure, lb	90354.00	87092.00
Hydrogen, lb	85162.00	85692.00
Oxygen, lb	544334.00	547713.00
Other, lb	2930.00	2961.00
Fuel, lb	632426.00	636366.00
Avionics, lb	---	9354.00
Hydraulics, lb	1593.00	692.00
Electronics, lb	3738.00	3967.00
Equipment, lb	34385.00	18973.00
Subsystems, lb	39716.00	32986.00
TOTAL TAKE OFF GROSS WEIGHT, lb	891795.00	897240.00

* Denotes Input

** Integral Tank Design $W_b = W_{tank}$

Table 10
VEHICLE CONFIGURATION: GENERAL DYNAMICS BOOSTER

GEOMETRY	Actual	Model
Vehicle Length, Forward Cone, ft	35.60	34.34
Vehicle Length, Cylinder, ft	174.40	168.01
Vehicle Length, Aft Cone, ft	---	---
TOTAL VEHICLE LENGTH, ft	210.00	202.37
Equivalent Diameter, ft	39.40	42.75
Length/Diameter	5.33	5.33
Wing Area, S_{ref} , ft ²	3459.00	3628.60
Wing Span, b, ft	201.00	205.87
Aspect Ratio = b^2/S_{ref}	11.68	11.68
Wing Loading,* W_{gtot}/S_{ref} *	137.75	137.75
Tail Area, ft ²	2283.00	2394.00
Body Wetted Area, ft ²	26610.00	23500.90
Volume Required, ft ³	236000.00	203371.90
Volume Payload, ft ³ *	0.00	0.00
WEIGHTS	Actual	Model
Payload, lb *	0.00	0.00
Fuel Tank, lb	131542.00	127643.00
Turbojet, lb	58485.00	39986.00
Ramjet, lb	---	---
Scramjet, lb	---	---
Rocket, lb	39600.00	68563.00
Propulsion, lb	229627.00	236193.00
Body, lb **	0.00	0.00
Wing, lb	41972.00	52804.00
Horiz., Vert. Tail, lb	24292.00	61623.00
Thermal Protection System, lb	41000.00	38214.00
Landing Gear, lb	20800.00	23311.00
Thrust Structure, lb	27194.00	18706.00
Structure, lb	155258.00	194658.00
Hydrogen, lb	374935.00	393301.00
Oxygen, lb	2437079.00	2556809.00
Other, lb	46781.00	48988.00
Fuel, lb	2858795.00	2999098.00
Avionics, lb	---	---
Hydraulics, lb	3104.00	15288.00
Electronics, lb	1545.00	976.00
Equipment, lb	86946.00	8234.00
Subsystems, lb	91595.00	44991.00
TOTAL TAKE OFF GROSS WEIGHT, lb	3402316.00	3499435.00

* Denotes Input

** Integral Tank Design $W_b = W_{tnk}$

Table 11
VEHICLE CONFIGURATION: MARTIN MARIETTA - PARALLEL BURN

GEOMETRY	Actual	Model
Vehicle Length, Forward Cone, ft	46.70	42.58
Vehicle Length, Cylinder, ft	102.90	93.66
Vehicle Length, Aft Cone, ft	---	---
TOTAL VEHICLE LENGTH, ft	149.40	136.27
Equivalent Diameter, ft	38.28	37.11
Length/Diameter	3.90	3.91
Wing Area, S_{ref} , ft ²	2226.00	2236.90
Wing Span, b, ft	114.60	114.54
Aspect Ratio = b^2/S_{ref}	3.87	3.87
Wing Loading, * W_{gtot}/S_{ref} *	123.00	123.00
Tail Area, ft ²	859.00	492.10
Body Wetted Area, ft ²	16406.00	13733.90
Volume Required, ft ³	---	103162.70
Volume Payload, ft ³ *	10603.00	10603.00
WEIGHTS	Actual	Model
Payload, lb *	65000.00	---
Fuel Tank, lb	---	---
Turbojet, lb	---	---
Ramjet, lb	---	---
Scramjet, lb	---	---
Rocket, lb	51174.00	17495.00
Propulsion, lb	51174.00	17495.00
Body, lb **	53893.00	68425.00
Wing, lb	13770.00	26425.00
Horiz., Vert. Tail, lb	2590.00	4299.00
Thermal Protection System, lb	35087.00	25946.00
Landing Gear, lb	7401.00	11987.00
Thrust Structure, lb	---	4070.00
Structure, lb	112741.00	72685.00
Hydrogen, lb	172822.00	173644.00
Oxygen, lb	1692000.00	1700451.00
Other, lb	185437.00	186264.00
Fuel, lb	2050260.00	2060359.00
Avionics, lb	4333.00	13215.00
Hydraulics, lb	2367.00	587.00
Electronics, lb	5849.00	6095.00
Equipment, lb	33883.00	33371.00
Subsystems, lb	46432.00	53268.00
TOTAL TAKE OFF GROSS WEIGHT, lb	2325607.00	2337232.00

* Denotes Input

** Integral Tank Design $W_b = W_{ink}$

**Table 12
VEHICLE CONFIGURATION: SST**

GEOMETRY	Actual	Model
Vehicle Length, Forward Cone, ft	47.05	48.48
Vehicle Length, Cylinder, ft	184.87	207.24
Vehicle Length, Aft Cone, ft	83.08	85.75
TOTAL VEHICLE LENGTH, ft	315.00	341.47
Equivalent Diameter, ft	12.46	13.17
Length/Diameter	25.28	26.63
Wing Area, S_{ref} , ft ²	8447.00	8712.40
Wing Span, b, ft	126.84	128.80
Aspect Ratio = b^2/S_{ref}	1.90	1.90
Wing Loading, * W_{glwl}/S_{ref} *	75.77	75.77
Tail Area, ft ²	1002.00	1144.30
Body Wetted Area, ft ²	---	11061.00
Volume Required, ft ³	---	32566.00
Volume Payload, ft ³ *	---	18940.00
WEIGHTS	Actual	Model
Payload, lb *	69058.00	69058.00
Fuel Tank, lb	---	5470.00
Turbofan, lb	51049.00	42386.00
Ramjet, lb	---	---
Scramjet, lb	---	---
Rocket, lb	---	---
Propulsion, lb	51049.00	47856.00
Body, lb	58915.00	90286.00
Wing, lb	76139.00	80691.00
Horiz., Vert. Tail, lb	12198.00	6385.00
Thermal Protection System, lb	0.00	0.00
Landing Gear, lb	26028.00	31854.00
Thrust Structure, lb	---	1382.00
Structure, lb	173280.00	210598.00
Hydrogen, lb	---	---
Oxygen, lb	---	---
Other, lb	303869.00	310794.00
Fuel, lb	303869.00	310794.00
Avionics, lb	2569.00	8373.00
Hydraulics, lb	5709.00	1235.00
Electronics, lb	6728.00	4076.00
Equipment, lb	27747.00	16601.00
Subsystem, lb	42744.00	30285.00
TOTAL TAKE OFF GROSS WEIGHT, lb	640000.00	660140.00

* Denotes Input

Table 13
VEHICLE CONFIGURATION: CH₄ TRANSPORT (M = 6)

GEOMETRY	Actual	Model
Vehicle Length, Forward Cone, ft	---	107.40
Vehicle Length, Cylinder, ft	---	266.70
Vehicle Length, Aft Cone, ft	---	35.30
TOTAL VEHICLE LENGTH, ft	---	409.40
Equivalent Diameter, ft	---	15.72
Length/Diameter *	---	27.30
Wing Area, S _{ref} , ft ²	---	6402.00
Wing Span, b, ft	---	119.80
Aspect Ratio = b ² /S _{ref} *	---	2.240
Wing Loading, W _{gut} /S _{ref} *	---	86.00
Tail Area, ft ²	---	1104.30
Body Wetted Area, ft ²	---	15953.00
Volume Required, ft ³	---	55610.00
Volume Payload, ft ³ *	---	13860.00
WEIGHTS	Actual	Model
Payload, lb *	---	42000.00
Fuel Tank, lb	---	20043.00
Turbojet, lb	---	13326.00
Ramjet, lb	---	1293.00
Scramjet, lb	---	---
Rocket, lb	---	---
Propulsion, lb	---	34662.00
Body, lb	---	74316.90
Wing, lb	---	60405.00
Horiz., Vert. Tail, lb	---	7919.70
Thermal Protection System, lb	---	22206.00
Landing Gear, lb	---	25975.00
Thrust Structure, lb	---	877.00
Structure, lb	---	191699.00
Hydrogen, lb	---	---
Oxygen, lb	---	---
Other, lb, CH ₄	---	253803.50
Fuel, lb	---	253803.50
Avionics, lb	---	7841.00
Hydraulics, lb	---	1196.00
Electronics, lb	---	3894.90
Equipment, lb	---	15505.50
Subsystems, lb	---	28438.00
TOTAL TAKE OFF GROSS WEIGHT, lb	---	550603.00

* Denotes Input

Table 14
VEHICLE CONFIGURATION: H₂ FIGHTER (M = 6)

GEOMETRY	Actual	Model
Vehicle Length, Forward Cone, ft	---	137.80
Vehicle Length, Cylinder, ft	---	11.80
Vehicle Length, Aft Cone, ft	---	35.60
TOTAL VEHICLE LENGTH, ft	185.00	185.20
Equivalent Diameter, ft	---	22.46
Length/Diameter *	---	6.04
Wing Area, S _{ref} , ft ²	---	3850.00
Wing Span, b, ft	---	80.85
Aspect Ratio = b ² /S _{ref} *	---	1.698
Wing Loading, W _{gtot} /S _{ref} *	---	80.78
Tail Area, ft ²	---	500.00
Body Wetted Area, ft ²	---	9673.00
Volume Required, ft ³	---	51380.00
Volume Payload, ft ³ *	---	1500.00
WEIGHTS	Actual	Model
Payload, lb *	---	5000.00
Fuel Tank, lb	---	34555.00
Turbojet, lb	---	0.00
Ramjet, lb	---	1500.00
Scramjet, lb	---	0.00
Rocket, lb	---	4571.00
Propulsion, lb	---	40627.00
Body, lb	---	33022.00
Wing, lb	---	25321.00
Horiz., Vert. Tail, lb	---	4378.00
Thermal Protection System, lb	---	8687.00
Landing Gear, lb	---	13670.00
Thrust Structure, lb	---	2194.00
Structure, lb	---	87272.00
Hydrogen, lb	---	155500.00
Oxygen, lb	---	---
Other, lb, CH ₄	---	---
Fuel, lb	---	155500.00
Avionics, lb	---	6380.00
Hydraulics, lb	---	706.90
Electronics, lb	---	2400.80
Equipment, lb	---	13110.00
Subsystems, lb	---	22598.00
TOTAL TAKE OFF GROSS WEIGHT, lb	320000.00	310997.00

* Denotes Input

Table 15
VEHICLE CONFIGURATION: CH₄ FIGHTER (M = 6)

GEOMETRY	Actual	Model
Vehicle Length, Forward Cone, ft	---	79.90
Vehicle Length, Cylinder, ft	---	198.30
Vehicle Length, Aft Cone, ft	---	26.30
TOTAL VEHICLE LENGTH, ft	---	304.50
Equivalent Diameter, ft	---	11.69
Length/Diameter *	---	27.28
Wing Area, S _w , Ref, ft ²	---	2965.00
Wing Span, b, ft	---	71.00
Aspect Ratio = b ² /S _w *	---	1.700
Wing Loading, W _{gtwl} /S _{ref} *	---	86.00
Tail Area, ft ²	---	511.50
Body Wetted Area, ft ²	---	8825.00
Volume Required, ft ³	---	22880.00
Volume Payload, ft ³ *	---	1602.00
WEIGHTS	Actual	Model
Payload, lb *	---	5000.00
Fuel Tank, lb	---	9283.00
Turbojet, lb	---	13326.00
Ramjet, lb	---	1293.00
Scramjet, lb	---	---
Rocket, lb	---	---
Propulsion, lb	---	23903.00
Body, lb	---	39910.00
Wing, lb	---	20374.00
Horiz., Vert. Tail, lb	---	3359.00
Thermal Protection System, lb	---	11362.00
Landing Gear, lb	---	10936.00
Thrust Structure, lb	---	877.00
Structure lb	---	86818.00
Hydrogen, lb	---	---
Oxygen, lb	---	---
Other, lb, CH ₄	---	117555.00
Fuel, lb	---	117555.00
Avionics, lb	---	5939.00
Hydraulics, lb	---	10935.00
Electronics, lb	---	2462.00
Equipment, lb	---	12550.00
Subsystems, lb	---	21730.00
TOTAL TAKE OFF GROSS WEIGHT, W _{gtot} /lb	---	255006.00

* Denotes Input

Table 16
EFFECT OF PAYLOAD CHANGE ON VEHICLE SIZE AND WEIGHT

VEHICLE		$W_{\text{pay}}/W_{\text{pay Design}}$						
		0.5	0.75	1	1.25	1.5	1.75	2
HYCAT CH ₄ FIGHTER	W_{gtot}	236800	245977	255000	264077	273065	281801	290668
	Length, ft	295	300	305	309	313	317	321
HYCAT 200 CH ₄ TRANSPORT	W_{gtot}	396126	473823	550549	628191	705196	781899	858919
	Length, ft	361	387	409	430	448	466	481
SST	W_{gtot}	460375	561242	660000	758352	855853	953407	1051516
	Length, ft	286	316	341	363	383	400	416
SHUTTLE	W_{gtot}	151875	189466	226328	262581	298414	333979	369329
	Length, ft	112	123	132	139	146	153	158
MMP. BURN	W_{gtot}	162830	1987251	2339336	2693302	3051656	3413065	3771780
	Length, ft	121	129	136	143	149	154	159
ROCKWELL	W_{gtot}	400794	452679	504000	555307	606360	657709	709377
	Length, ft	269	283	295	306	316	326	335
HYCAT 1A	W_{gtot}	504392	557470	610406	663423	715778	767659	819994
	Length, ft	325	338	351	362	373	383	392
HYCAT 1	W_{gtot}	579221	638255	697000	755774	813789	871020	928556
	Length, ft	368	382	396	408	420	431	441
HYCAT 4	W_{gtot}	839234	910080	981981	1053141	1124922	1196806	1268207
	Length, ft	368	380	391	402	412	422	431
GD ORBITER	W_{gtot}	696397	796313	897000	998245	1099847	1202119	1306082
	Length, ft	153	159	166	172	177	183	188
GD BOOSTER	W_{gtot}	3502498	3502498	3502498	3502498	3502498	3502498	3502498
	Length, ft	202	202	202	202	202	202	202
H ₂ FIGHTER	W_{gtot}	285072	297903	311000	---	---	---	---
	Length, ft	179	182	185	---	---	---	---

Note Payload volume and weight varied by same factor

Table 17
EFFECT OF FUEL LOADING ON VEHICLE SIZE AND WEIGHT

VEHICLE		$W_{fuel}/W_{fuel\ Design}$				
		0.8	0.9	1	1.1	1.2
HYCAT CH ₄ FIGHTER	W_{gtot}	174903	207707	255000	329445	463251
	Length, ft	279	290	305	325	356
HYCAT 200 CH ₄ TRANSPORT	W_{gtot}	372665	444433	550549	728336	1092634
	Length, ft	378	391	409	437	486
SST *	W_{gtot}	489792	562178	660000	801219	1022498
	Length, ft	327	334	341	352	368
SHUTTLE * *	W_{gtot}	226328	226328	226328	226328	226328
	Length, ft	132	132	132	132	132
MM P. BURN	W_{gtot}	1755336	2009251	2339336	2797543	3481970
	Length, ft	124	130	136	145	155
ROCKWELL	W_{gtot}	399459	445638	504000	579643	682259
	Length, ft	275	284	295	308	324
HYCAT 1A	W_{gtot}	437587	509974	610406	760015	1005448
	Length, ft	317	332	350	375	410
HYCAT 1	W_{gtot}	475917	566044	697000	905642	1289970
	Length, ft	352	371	395.7	429	481
HYCAT 4	W_{gtot}	626406	764666	981980	1380615	2445104
	Length, ft	340	362	392	436.6	526
GD ORBITER	W_{gtot}	754307	825518	897000	981427	1084571
	Length, ft	158	162	166	170	176
GD BOOSTER	W_{gtot}	2259607	2749235	3502498	4880613	8516036
	Length, ft	176	187	202	225	270
H ₂ FIGHTER	W_{gtot}	144070	198248	311000	---	---
	Length, ft	143	159	185	---	---

- * Fuel in wing
- * * Shuttle orbiter does not have appreciable fuel on board



Report Documentation Page

1. Report No. NASA CR-182226		2. Government Accession No.		3. Recipient's Catalog No.	
4. Title and Subtitle HASA—Hypersonic Aerospace Sizing Analysis for the Preliminary Design of Aerospace Vehicles				5. Report Date November 1988	
				6. Performing Organization Code	
7. Author(s) Gary J. Harloff and Brian M. Berkowitz				8. Performing Organization Report No. None (E-4496)	
9. Performing Organization Name and Address Sverdrup Technology, Inc. NASA Lewis Research Center Group Cleveland, Ohio 44135				10. Work Unit No. 505-69-61	
				11. Contract or Grant No. NAS3-24105	
12. Sponsoring Agency Name and Address National Aeronautics and Space Administration Lewis Research Center Cleveland, Ohio 44135-3191				13. Type of Report and Period Covered Contractor Report Final	
				14. Sponsoring Agency Code	
15. Supplementary Notes Project Manager, Arthur J. Glassman, Aeropropulsion Analysis Office, NASA Lewis Research Center.					
16. Abstract <p>A review of the hypersonic literature indicated that a general weight and sizing analysis was not available for hypersonic orbital, transport, and fighter vehicles. The objective of this study was to develop such a method for the preliminary design of aerospace vehicles. This report describes the developed methodology, and provides examples to illustrate the model, entitled the Hypersonic Aerospace Sizing Analysis (HASA). It can be used to predict the size and weight of hypersonic single-stage and two-stage-to-orbit vehicles and transports, and is also relevant for supersonic transports. HASA is a sizing analysis that determines vehicle length and volume, consistent with body, fuel, structural, and payload weights. The vehicle component weights are obtained from statistical equations for the body, wing, tail, thermal protection system, landing gear, thrust structure, engine, fuel tank, hydraulic system, avionics, electrical system, equipment payload, and propellant. Sample size and weight predictions are given for the Space Shuttle orbiter and other proposed vehicles, including four hypersonic transports, a Mach 6 fighter, a supersonic transport (SST), a single-stage-to-orbit (SSTO) vehicle, a two-stage Space Shuttle with a booster and an orbiter, and two methane-fueled vehicles. In addition, sample calculations of the size and weight of the vehicles are presented for various fuel and payload mass fractions. The propulsion systems considered include turbojets, turboramjets, ramjets, scramjets, and liquid-fuel rocket engines; the fuels include JP 4, RP 1, liquid hydrogen, liquid oxygen, liquid methane, hydrazine, and nitrogen tetroxide. The results indicate that the method is accurate enough, $\pm 10\%$ of vehicle gross weight and length, to be used in preliminary designs and can predict absolute values and trends for hypersonic orbital, transport, and fighter vehicles. The model allows growth studies to be conducted with ease; examples of such studies are demonstrated herein.</p>					
17. Key Words (Suggested by Author(s)) Hypersonic transports Single-stage-to-orbit Vehicle weights			18. Distribution Statement Unclassified - Unlimited Subject Category 05		
19. Security Classif (of this report) Unclassified		20. Security Classif (of this page) Unclassified		21. No of pages 60	22. Price* A04

**END
DATE
FILMED**

MAR 24 1989